

Keyway Broaching

By Dick Kostelnicek

for

The Home Metal Shop Club

Presented March 13, 2010

Broached Products



Source: Hassay- Savage Corp.

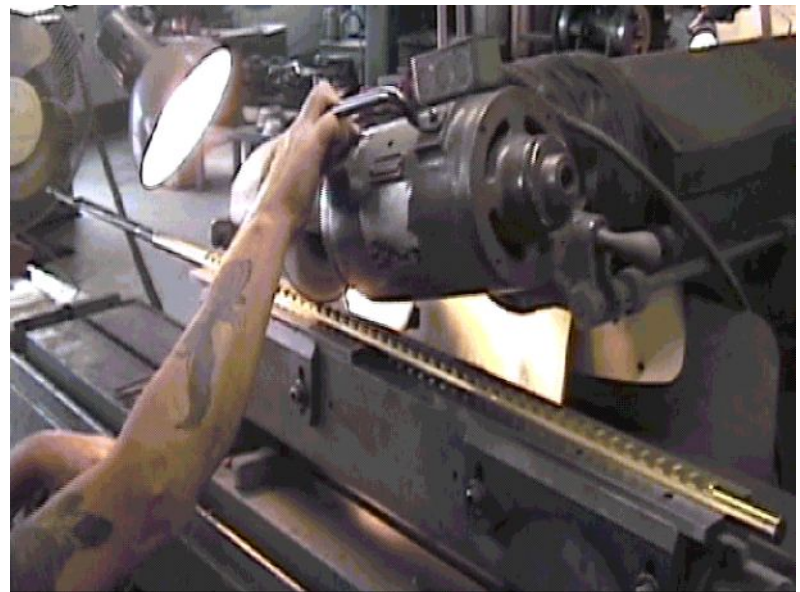
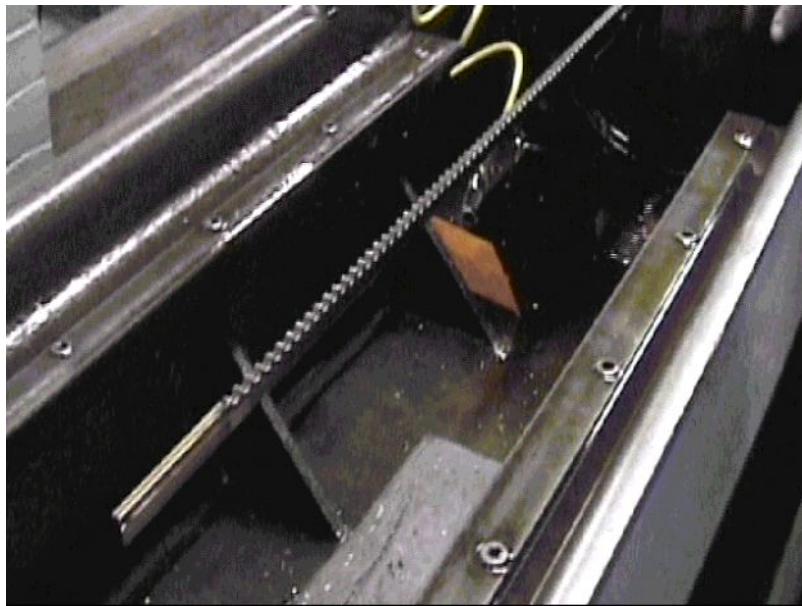

By Dick Kostelnicek 03-05-2010

Source: Center Broach and Machine Company, Inc

Broaching Hierarchy

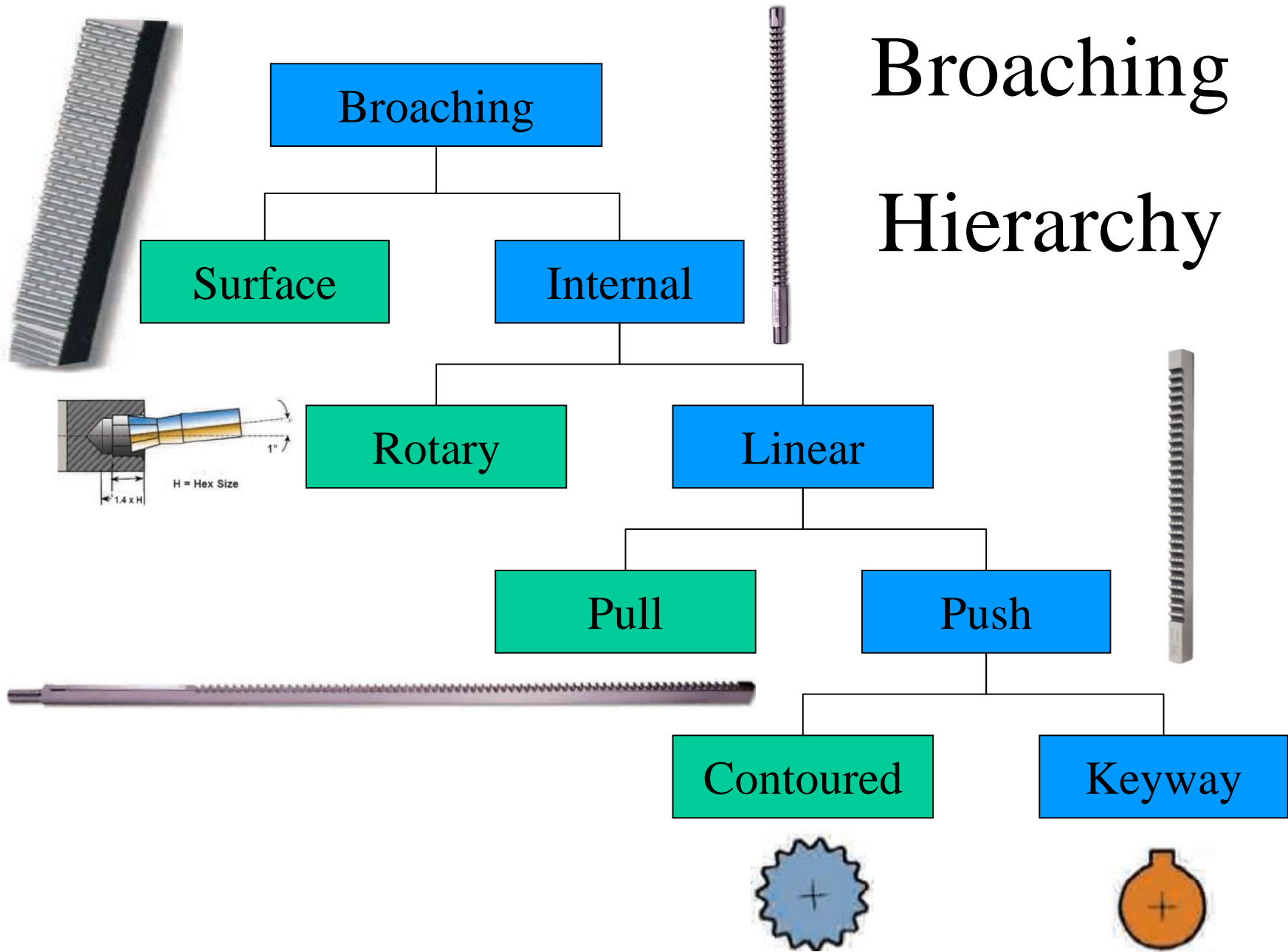

Broach Parts and Process

- The Broach is a Metal Cutting Form Tool
- Has Progressive Teeth (rough, fine, and burnish)
- Feed (tooth rise) is built into the tool
- Work is Usually Stationary
- Chips are Carried Away in Tool Gullets

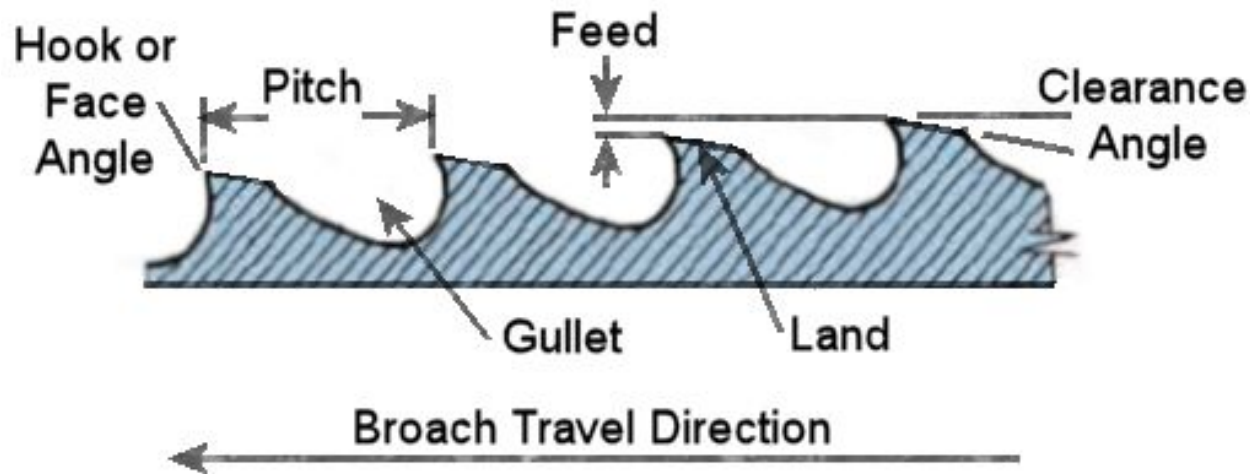

Standard Square Keys

S	E	
Over	Including	
5/16	7/16	3/32
7/16	9/16	1/8
9/16	7/8	3/16
7/8	1-1/4	1/4
1-1/4	1-3/8	5/16
1-3/8	1-3/4	3/8
1-3/4	2-1/4	1/2

dimensions in inches

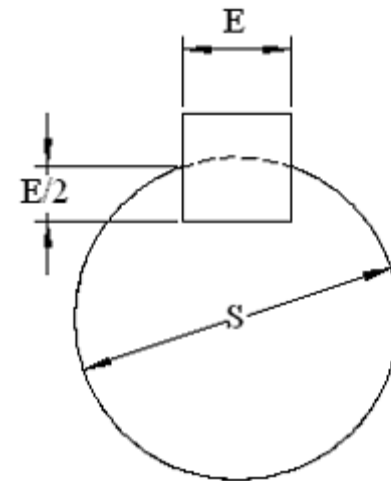

Square Keyway Broaching

Note: Tables for distance **M** are available in Machinery's Handbook

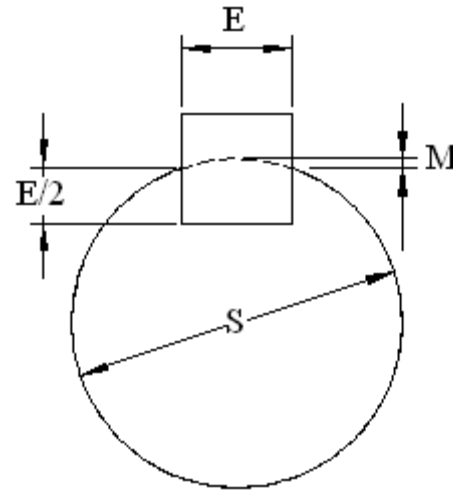

Tools for Keyway Broaching



Arbor Press



Shims



Collared Bushing

Plain Bushing



Push Keyway Broach

Keyway Push Broach Assembly

First Pass
Without Shim



Second Pass
With Shim

Materials Cut by Keyway Broaching

- Hardness less than Rockwell 35
- Brass & copper may exhibit depth drift
- Soft materials (aluminum) yield poor finish

Broaching Hints

- Two or more teeth contact the work
- Bushing extends through the work
- Align broach with ram travel
- Catch broach as it passes through the work
- Remove cuttings before second pass
- Lube shim face before second pass

Broach Lubrication

- Reduces Friction that Causes Chatter
- Aids in Chip Transport and Removal

Steel:	Cutting oil or water soluble coolant
Brass:	Dry or water
Cast Iron:	Dry
Aluminum:	Tap cutting fluid for aluminum

Note: Always lube the back and sides of a Keyway broach

Keyway Broaching Video



Part 1



Part 2

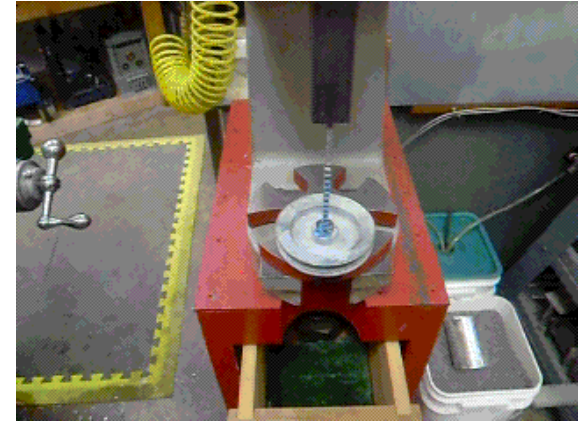

Part 3



Part 4

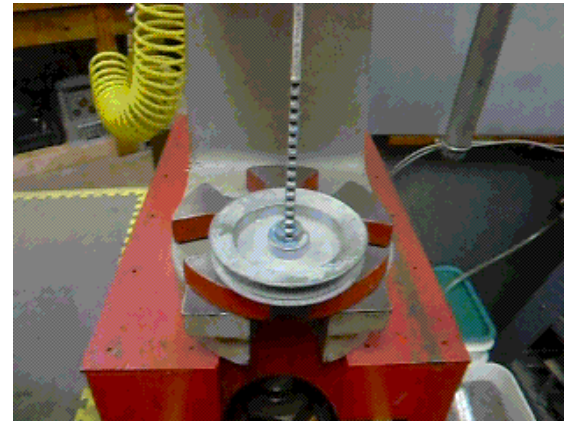

Part 5

Square Hole Broaching Video

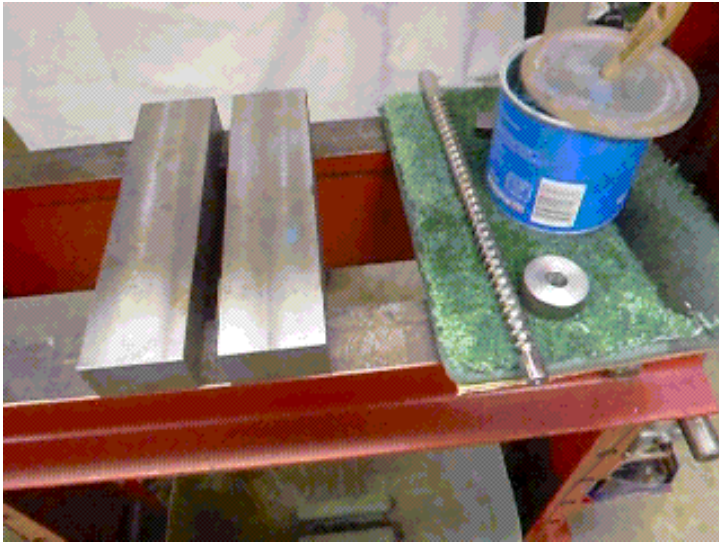

Pat 1

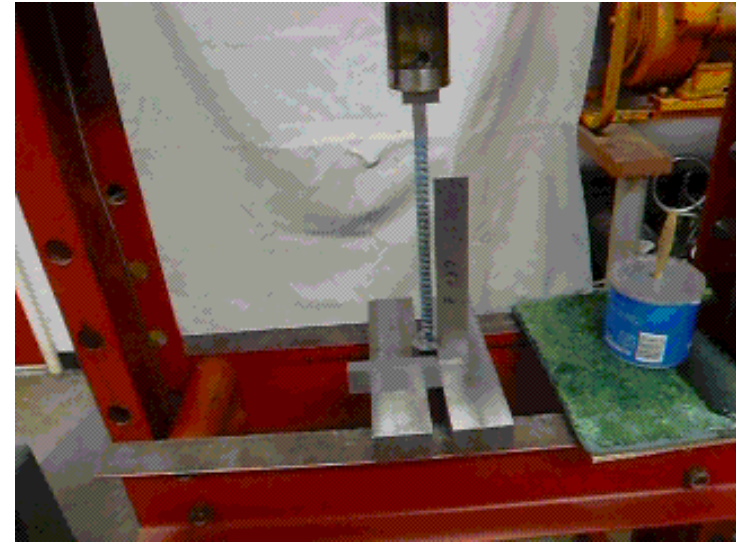

Part 2

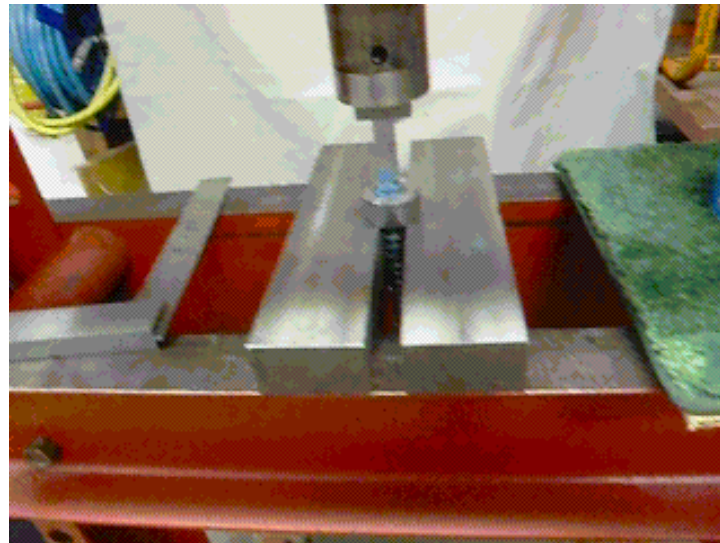

Part 3

el fin