

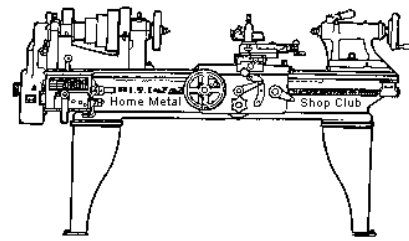

**July 2011**  
Newsletter

Volume 16 - Number 7



<http://www.homemetalsclub.org/>

Since its founding by John Korman in 1996, The Home Metal Shop Club has brought together metal workers from all over the Southeast Texas area.

Our members' interests include Model Engineering, Casting, Blacksmithing, Gunsmithing, Sheet Metal Fabrication, Robotics, CNC, Welding, Metal Art, and others. Members always like to talk about their craft and shops. Shops range from full machine shops to those limited to a bench vise and hacksaw.

If you like to make things, run metal working machines, or just talk about tools, this is your place. Meetings generally consist of a presentation with Q&A, followed by **show and tell** where the members can share their work and experiences.

President <i>Vance Burns</i>	Vice President <i>John Hoff</i>	Secretary <i>Martin Kennedy</i>	Treasurer <i>Emmett Carstens</i>	Librarian <i>Dan Harper</i>
Webmaster/Editor <i>Dick Kostelnicek</i>	Photographer <i>Jan Rowland</i>	CNC SIG <i>Dennis Cranston</i>	Casting SIG <i>Tom Moore</i>	Novice SIG <i>Rich Pichler</i>

## About the Upcoming August 13 Meeting

General meetings are usually held on the second Saturday of each month at 12:00 noon in the meeting rooms of the Parker Williams County Library, 10851 Scarsdale Boulevard, Houston, TX 77089. This month's meeting will be held on August 13<sup>th</sup>. Visit our [website](#) for up-to-the-minute details.

For the presentation, Vance Burns will speak on Metallurgy. At the Novice Meeting, Dick Kostelnicek will demonstrate how to disassemble and clean both 3-jaw scroll and Jacobs chucks.

## Recap of the July 9 General Meeting

By Martin Kennedy, with photos by Jan Rowland and Martin Kennedy



Twenty-six of our 53 members and no visitors attended the 12:00 noon meeting at the Parker Williams County Library. President *Vance Burns* led the meeting. Vance began the meeting with several topics of club business.

An appeal was made for books for our library, especially older books. If you would like to donate a book, please contact the librarian [Dan Harper](#).

A video of the meeting is [available on the club's web site](#). Older meeting videos have been removed from the website to make

room for the latest ones. All older videos are still available in the club's library on DVD.

Ideas for programs at our monthly meeting are always welcome. If you have an idea for a meeting topic, or if you know someone that could make a presentation, please contact [John Hoff](#).

Vance has a friend who is selling two lathes, a 12 x 24-inch Colchester Dominion and a Logan 10 x 24-inch. Contact [Vance](#) for more information.

## Presentation



*Chris Leard* has a shop that restores cars, old gas pumps, and soda dispensers. Most of the gas pumps he restores were in service in the 1930s and 1940s. Popular Coke machines are round top machines from pre 1960s and square top machines from the 1960s.

Chris does about 95% of the restorations on machines provided by customers. He used to acquire equipment, restore and sell outright, but this became too time consuming. The restored equipment is usually installed in game rooms or commercially in restaurants that desire a nostalgic look.

For a typical restoration, Chris strips the machine to bare metal using sugar sandblasting sand. He has to be very careful during the sandblasting operation, going slowly, as it is very easy to warp the thin sheet metal either from heat or from the peening of the metal with the sand. The large flat side panels on Coke machines are particularly prone to warping. He holds the sandblasting nozzle at an angle to the metal, using a pressure of about 100 psi. Chris purchases his sugar sand from [T Tex](#). An 80 lb bag is about \$8.



Alternately, Chris takes the equipment to a commercial operation that removes all paint with a phosphoric acid dip. The only disadvantage to this method is that the acid can get into crevices, and sometimes weeps through the finished paint job and leaves a rust stain. After sandblasting, Chris paints the machine. The color is selected to match an original paint scheme, based on research from reference books. For restoration of embossed lettering, such as on a Coke machine, Chris first paints the embossed area with white paint. He then paints over the entire area with red. The final operation is to carefully sand away the red paint in the embossed area to reveal the white paint underneath.

The last operation is to restore the mechanical systems. For the gas pumps, the heavy pump mechanism is removed and typically replaced with shelves. On the coke machines, the mechanism is restored to operational condition.

Due to the popularity of these old machines and the availability of reproductions, parts are readily available. For the soda machines, a good source is [Funtronics](#) in Illinois. For the gas pumps, a good source is [Vic's 66](#) in Washington State

The cost for a restoration is on the order of \$2000 for the restoration itself, plus \$500-\$2000 for the machine. Another popular restoration is of old picnic coolers, which cost about \$300-400 total restored. If the equipment has a lot of chrome, the cost can be higher. Gas pumps with a lot of chrome can cost over \$500 just to replat the chrome.

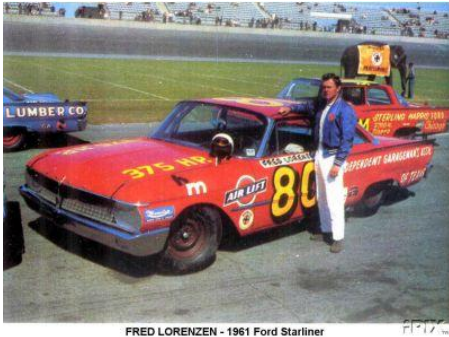

FRED LORENZEN - 1961 Ford Starliner

Chris also restores cars. His proudest possession is a 1961 Ford Starliner that was a winning car in NASCAR races in the early 1960s. He also has a 1925 Ford Model "T" that he's restoring.

Chris is not interested in restoring equipment much newer than the 1960s. Newer equipment is filled with complicated electronics instead of mechanical systems, and they usually require replacement of all the electronics. This can be quite costly.

## Show & Tell

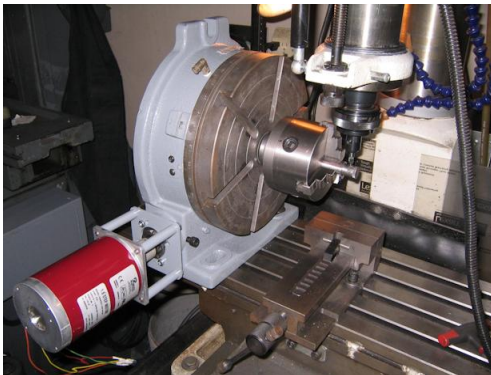

*Martin Kennedy* showed a Fourth rotary axis that he added to his CNC mill. He showed some engraving that he had done on a circular rod. The engraving was from a pen and ink drawing, which he scanned. The resultant raster drawing was converted to a vector drawing using Adobe Illustrator. The vector drawing was pulled into his CAM program, and G-code was created using axis substitution.

He also showed a digital camera that can be mounted on the spindle of his mill. An article on the camera and the drawings he used to build it are shown below in this newsletter.

*John Hoff* passed around a simple carbide scraper that he built.

*Dick Kostelnicek* adapted a [Kill A Watt](#) meter that he purchased for about \$20 to work with 220V instead of the designed 120V. This meter shows voltage, current, amps, VAs, frequency, power factor and kwh. When researching this meter, he was surprised that there was not a 220v version available. His solution was to make a box that allows the meter's use with 220v appliances. An article covering this conversion will be in the August newsletter.

For fun, Dick measured how much power it took to cut metal. He did this by comparing the idle power demand to the value captured while cutting metal. He found that it takes about 5.8 hp per cubic inch per second to cut metal on his mill. He was surprised to find that about 60% of energy required by his lathe was while it was idle and has only reflected a 0.5 power factor.

*Alan May* brought in a beautifully made Sterling Engine. He recently completed the engine after working on it for about one year. The engine was built using plans from Jerry Howell. Alan also bought a kit, containing only six ball bearings and a chunk of carbon. The trickiest part of the build was getting good alignment on the piston connecting rod. Like all Sterling engines, all friction must be absolutely minimized for the engine to operate. After repairing a part that became loose during transport to the meeting, he ran the engine using a small alcohol burner.

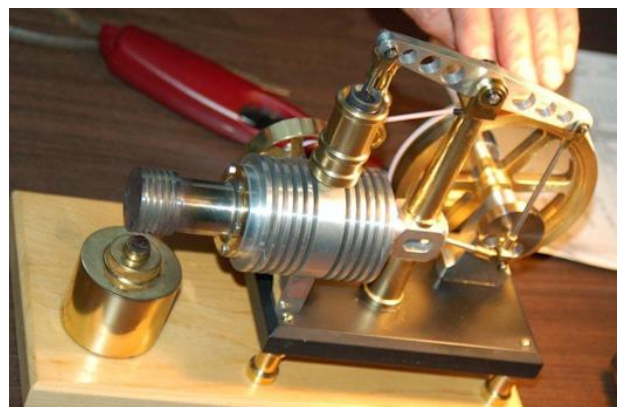

Alan also passed on a tip to use two chuck keys at once when you adjust a four jaw chucks. He said that using that technique made it much easier for him to get a part centered.

*Rich Pichler* brought some of his garage sale acquisitions, including a tiny tap set for several sizes of screws smaller than #1, and an end mill sharpening adapter for a surface grinder

*Jan Rowland* brought more free hardware stuff. Thanks again, Jan!



*Joe Scott* brought in a rare Pratt Bernard push collet for a lathe. Unlike a conventional collet that is drawn in towards the lathe spindle when engaged, the push collet uses a moving piece that moves forward on the collet. This leaves the part in exactly the same place, instead of moving it slightly towards the spindle, and is very useful on production or turret lathes. Joe uses the collet for making small screws.

Joe recommended a website - [Shipsnostalgia](#) and in particular the photos of large machines from [William Doxford and Sons](#).

*Joe Williams* brought a precursor to collets, a 70-year-old set of adapters from Browne and Sharpe. He also had a 1-inch square, 7-inch long high speed steel tool blank for a really big lathe.

*Lee Morin* went through the detailed steps of the machining operations on a display mount that he was building, and solicited member input on improving the process. The mount was to connect back plates for displays used in NASA's Orion spacecraft to a tubing frame. He is building the mounts for two reasons. First, he wanted a training exercise on precision machining operations, using something that didn't necessarily need to be precision. Second, he needed a total of 9 mounts, 6 angled and 3 flat. Commercially built, they cost over \$300 each.

*Mike Hancock* had a touch off probe that he made for his CNC mill. He plans to use the probe to easily set the zero on the Z-axis. He also plans to write a small program using the G31 code to find the probe, and then G92 to reset the zero.

An interesting [video](#) was shown on preparation for duck hunting.

## Problems and Solutions

A member needed an acme screw for a word-working vise, and requested a supplier for the screw since the one he found was very expensive. He was referred to Wholesale Tools and to [Ball screws and actuators](#) which sell Acme screws by the foot.

A member asked for instructions on how to grind a fly bit to cut a gear tooth. He could use a Dremel to grind a piece of tool steel, checking it often against good gear teeth. Then he could lap the gears when finished with Clover grinding compound to assure a good fit. Another suggestion in the group's Tinkering Yahoo group mentioned this [website](#).

## Novice SIG Activities



*Rich Pichler* demonstrated the use of a milling attachment on the club's lathe, and how to align four jaw chucks.

The August Novice activity will be to take apart and clean a 3-jaw lathe chuck. Dick Kostelnicek will fill in for Rich Pichler.

## Articles

### Quick Drill Guide

*By J. R. Williams*

Drilling a cross hole in a round bar is a simple job when your milling machine is working. Mine has been out of service for a while. I had a project to cut a keyway in a coupling that was larger than my keyway broach set so the next method was to use a shaper. I had a tool holder from previous jobs but it was not long enough. I turned a new longer holder from a quality bolt. Normally I would have made a square hole in the end of the bar using my milling machine. The next method was to use a section of an old end mill cutter as the cutter and drill a matching hole in the new bar. A short section of steel was turned to the same diameter as the bar and drilled with the required size drill.



Holding the work and the guide in the vise, allowed the hole to be in the center of the bar and square (left photo). I moved the work over to the center of the vise before drilling through the work.



The finished project is shown in the right photo. The work piece had a 1-5/8 inch diameter hole and the keyway was cut at the top of the bore. The shaper's clapper box was secured for the job and the cut was on the forward stroke.

## Spindle Camera

By Martin Kennedy

I have a round column mill CNC conversion from [CNC Masters](#) called a CNC Jr. It is based on one of the many copies of the Rong Fu RF-31 mill.

Vertical adjustment of the tool bit can be accomplished two ways – use of the quill or readjustment of the head. This requires loosening and tightening two bolts. Many larger mills have a fixed head, with a quill and a knee for adjustment. A knee allows movement of the table vertically. On my mill, the quill has about 5” of total travel. Occasionally, I use two tools, say a mill and a chucking reamer mounted in a chuck, and the difference in the lengths of the tools can exceed 5”. Even with careful planning, I still have to move the head.

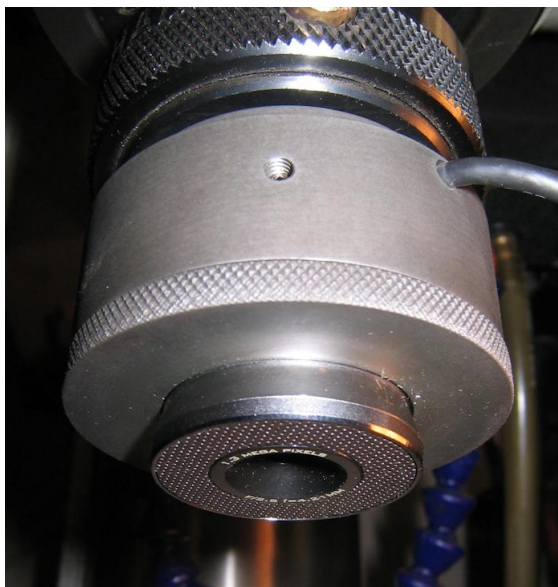

Since the mill has a round column, any zero X-Y alignment that was set before the head movement must be reset after movement. I looked for a way to accomplish this quickly and easily. I ran across discussion on a *Spindle Camera*, which led me to a piece of software called [CentreCam](#), and some pictures of cameras that people had built.

The video camera mounts vertically on the spindle and looks directly down at the workface. I could use the camera to set the initial zero, and then quickly reset it after head movement. It also looked like an interesting project, so I designed and built one.

There are certainly other ways of aligning the mill, but while they're more accurate, they're also slower. For more on these other methods, see the videos I filmed of my friend Joe [here](#), [here](#), and [here](#).

Two pieces of software are available that make the video camera much more versatile than the video software that comes with the camera. These programs include cross hairs and other alignment and measurement tools. I've tried both the viewer that comes with Mach3, and the shareware viewer called CentreCam. CentreCam is slightly more useful, as it includes the ability to have two equally spaced vertical or horizontal lines projected on the screen. Both programs include crosshairs, measurement tools and as a circle with a user definable size. These tools make centering objects very easy.

I started my design by purchasing a suitable video camera. I bought [a Creative Live! Cam Video IM Ultra Webcam](#) for several reasons: it was very small, it had a 640 x 480 native resolution (required by CentreCam), and most importantly, it had a price after rebate of less than \$10! I had to remove the camera from the original enclosure. I reused both the camera electronics and the focus bezel. It had a built-in microphone which I didn't use. If you build a spindle camera, be sure that the camera you select has a minimum native resolution of 640 x 480. Many inexpensive cameras have a native resolution half this size, but claim the larger resolution since they can do it through software. If you want to use my design, you'll need to obtain the same camera I used, or a related model from the same company that's the same size. Also be sure that your camera has manual, not automatic focus. You'll need to focus on objects less than 1" away, and the auto focus cameras can't do this.

I went through several designs. Initially, I made an oval design that I decided would be too hard to machine. I ended up with a round design. I made it just big enough to contain the camera. I designed a mounting ring for the camera that allowed X-Y adjustment, as well as azimuth. You'll note that my design includes a quick-connect adaptor for my quick connect system. It's not a very popular one, so you'll likely have to redesign this or just put in something like a 1/2" rod that can be accurately chucked in your mill. One of the hard things to machine is the internal and external threads of the camera enclosure. If you don't want to try threading, use a slip connection and bolts or set screws.

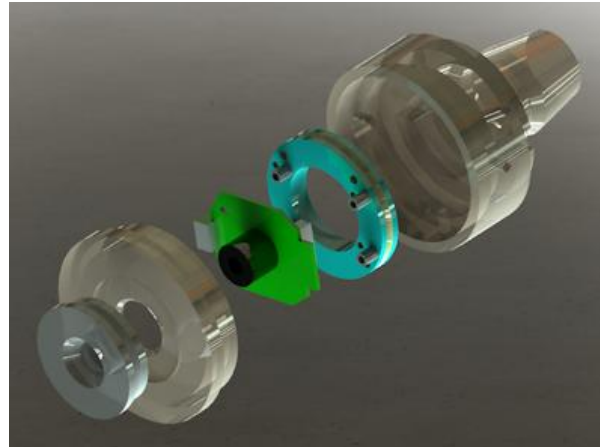

Another change to the design you may want to make is to add led lights for better illumination. I was able to move the light on my mill around, and this worked for me.

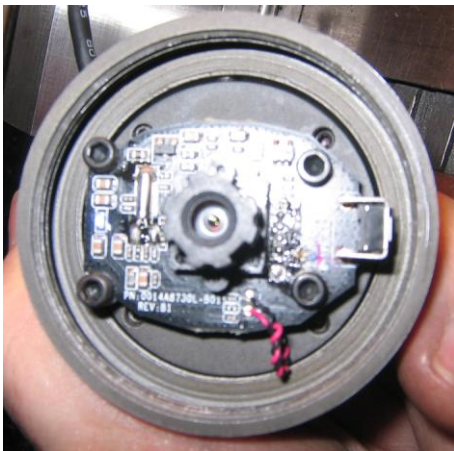

I've tried to measure the accuracy of the camera. I suspect that it's at least +/- 0.005", which is accurate enough for most uses. Some of the readings I took showed it better than +/- 0.002". I know that when you use it to center on a punch mark, the punch mark is huge! It's also great to find the center of a hole for re-entry.

You'll have to align the camera after you complete the project. Align your mill to the corner of your vice using a conventional edge finder. Install the camera and run it down as close as

you can focus on the corner of the vice. Set the X-Y adjustment using the X-Y set screws. Now run the spindle up as far as you can and refocus the camera. If the corner of the vice is not still aligned, use the set screws inside of the camera to adjust the azimuth. Repeat until no additional adjustment is needed.

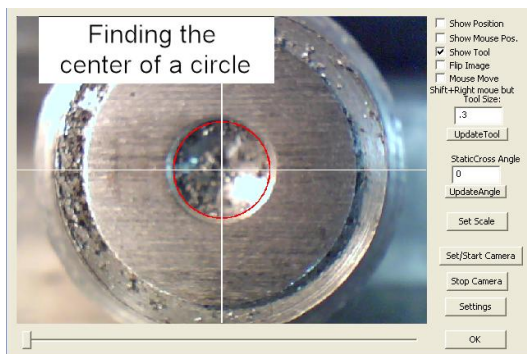
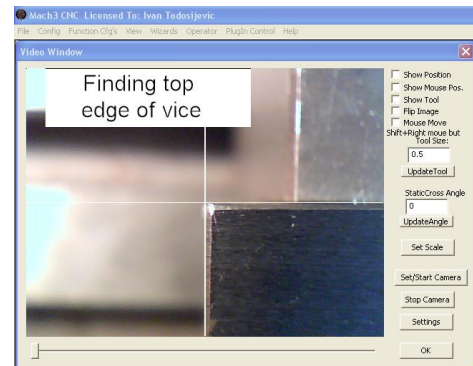

The screen shots are from Mach3. Access camera by selecting "Plugin Control" from Main Screen, then "Video Window"

Plans for the camera are shown below or at the [web link](#):

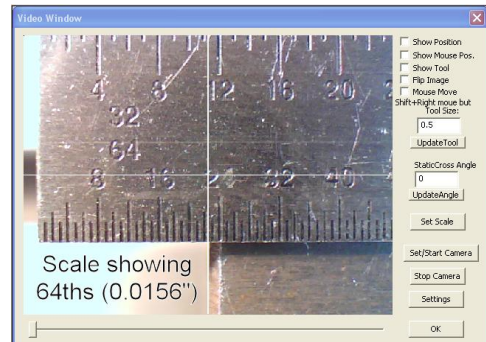

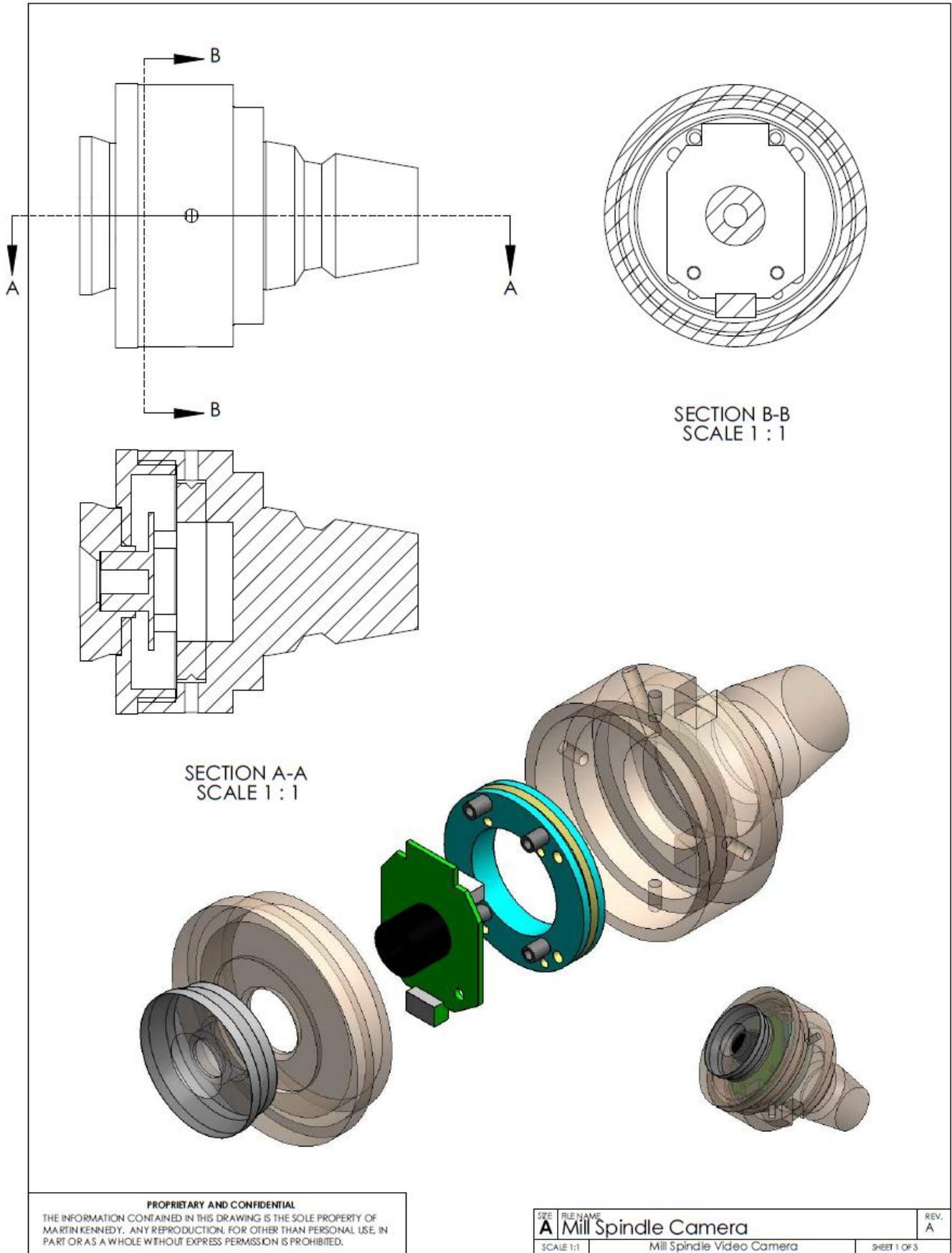



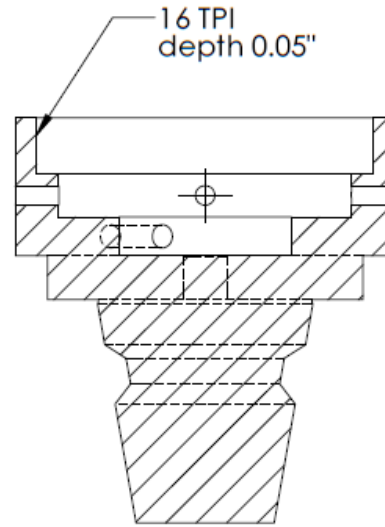
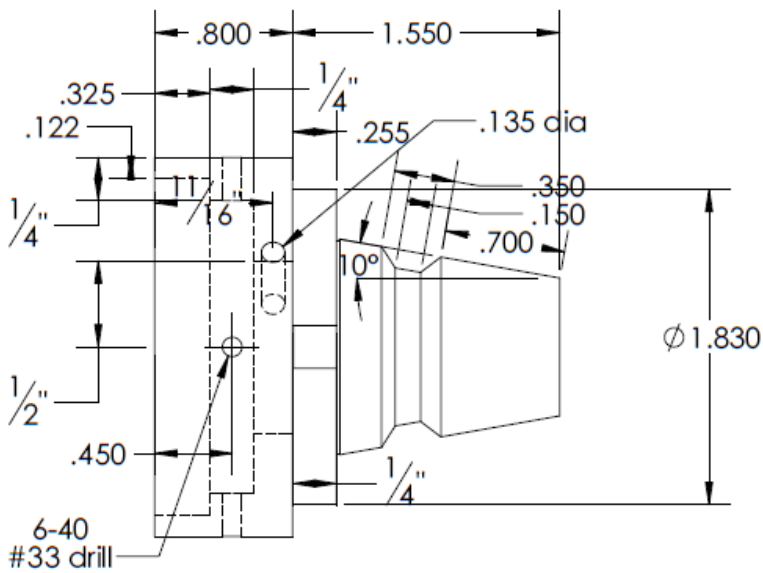
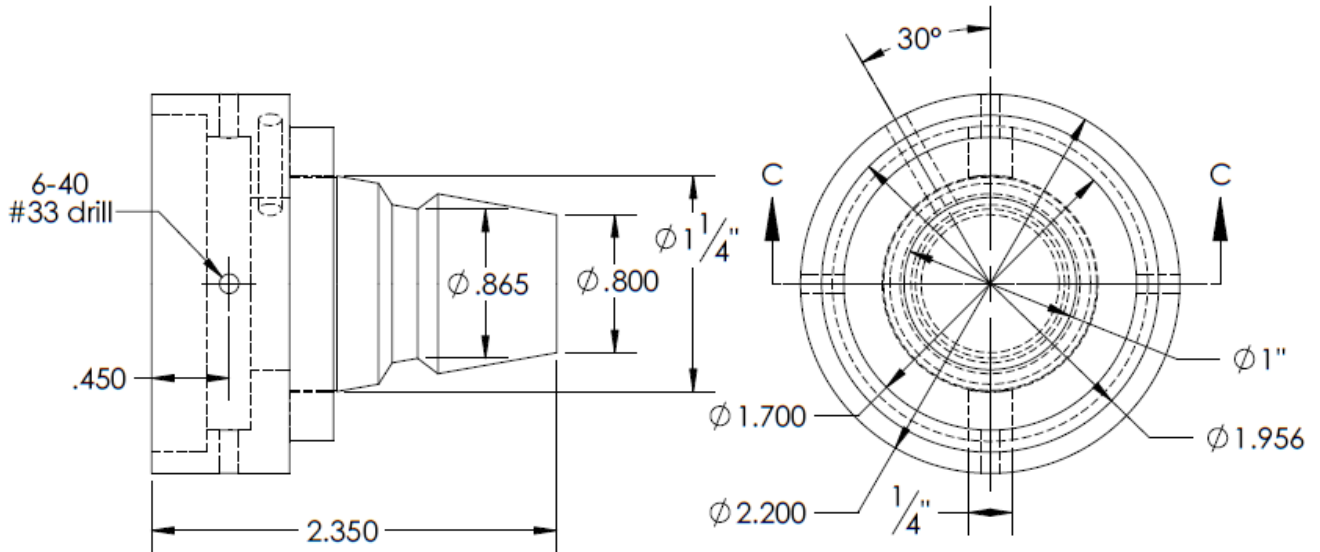

Note: Cap screws on with 16 TPI threads.  
Alternate design would use slip on cap  
with set screws, and would be much  
easier to fabricate!



**PROPRIETARY AND CONFIDENTIAL**

THE INFORMATION CONTAINED IN THIS DRAWING IS THE SOLE PROPERTY OF MARTIN KENNEDY. ANY REPRODUCTION, FOR OTHER THAN PERSONAL USE, IN PART OR AS A WHOLE WITHOUT EXPRESS PERMISSION IS PROHIBITED.

SIZE	FILE NAME	REV.
A	Mill Spindle Camera	A
SCALE 1:1	Main Camera Body	SHEET 2 OF 3

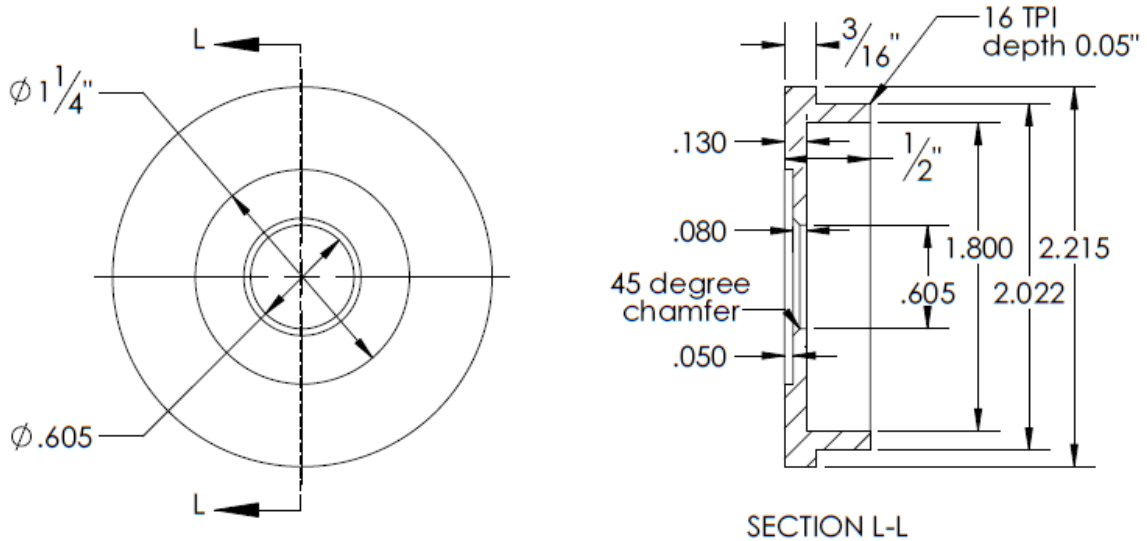

**Housing Cap**

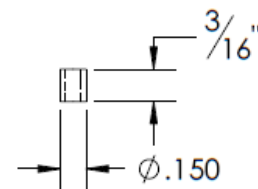
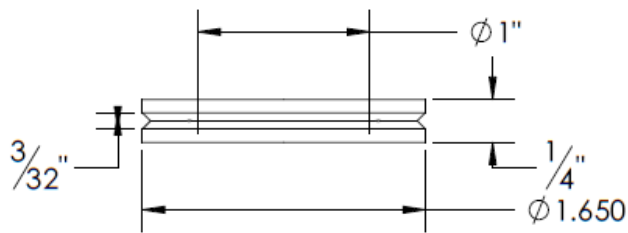

**Spacers  
4 req'd**

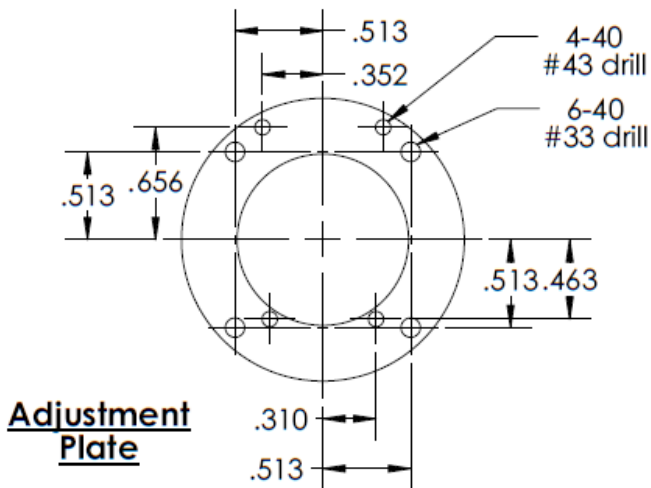

**Adjustment  
Plate**

**PROPRIETARY AND CONFIDENTIAL**

THE INFORMATION CONTAINED IN THIS DRAWING IS THE SOLE PROPERTY OF MARTIN KENNEDY. ANY REPRODUCTION, FOR OTHER THAN PERSONAL USE, IN PART OR AS A WHOLE WITHOUT EXPRESS PERMISSION IS PROHIBITED.

SIZE <b>A</b>	FILE NAME Mill Spindle Camera	REV. A
SCALE 1:1	Housing Cap & Adjustment Plate	SHEET 3 OF 3

## Chisel Fixture for Surface Grinder

By Dick Kostelnicek



I rough grind woodworking hand chisels with the aid of a holding fixture that magnetically clamps to the table of a surface grinder (photo left). This allows me to make a perfectly flat top face on the chisel's tapered cutting edge. However, I still have to hone the chisel's edge by hand with a wet stone to achieve razor sharpness and remove the burr from its backside.

Chisel edge forming is done with the surface grinder rather than, as in the past, by off-hand pedestal grinding. Note that a surface grinder produces a flat face rather than the concaved surface made by the pedestal's wheel.

This fixture accommodates chisels from 1/4 to 1-1/4 inches wide. Hand chisels usually come in widths of 1/4 inch increments. There are 5 setscrew positions that allow any chisel to be clamped at its mid section.

When you purchase a new chisel, the face angle is usually 25 degrees. I like my chisel point to be a bit more aggressive at 20 degrees. This fixture helps to remove the bulk of the material from a new chisel to produce the slimmer edge. The drawings below indicate that the fixture's base was made from mild steel since it must be held magnetically by the surface grinder's chuck. The top clamp was made from aluminum because of its machinability. The undercut portion of the clamp was produced with a Woodruff key cutter.

If you don't want to build this fixture or you lack access to a surface grinder, you can use a stationary belt or disk sander along with a square guide block to align a chisel vertically against the sander's belt (right photo). If the chisel's handle rests on the sander's table, place a piece of key stock under the blade in order to raise its height so the side of the blade remains parallel to the table.

The sander's belt or disk will carry away much of the generated heat. However, you should frequently cool the chisel's edge with water since excess heat can destroy hardness. If the chisel's backside, near the point, turns dark brown or blue, the chisel may no longer hold a sharp edge. Fortunately, my surface grinder has flood cooling to help maintain the edge's hardness while grinding.



