

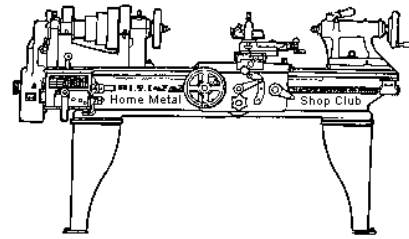

September 2011 Newsletter

Volume 16 - Number 9



<http://www.homemetalsclub.org/>

Since its founding by John Korman in 1996, The Home Metal Shop Club has brought together metal workers from all over the Southeast Texas area.

Our members' interests include Model Engineering, Casting, Blacksmithing, Gunsmithing, Sheet Metal Fabrication, Robotics, CNC, Welding, Metal Art, and others. Members always like to talk about their craft and shops. Shops range from full machine shops to those limited to a bench vise and hacksaw.

If you like to make things, run metal working machines, or just talk about tools, this is your place. Meetings generally consist of a presentation with Q&A, followed by **show and tell** where the members can share their work and experiences.

President <i>Vance Burns</i>	Vice President <i>John Hoff</i>	Secretary <i>Martin Kennedy</i>	Treasurer <i>Emmett Carstens</i>	Librarian <i>Dan Harper</i>
Webmaster/Editor <i>Dick Kostelnicek</i>	Photographer <i>Jan Rowland</i>	CNC SIG <i>Dennis Cranston</i>	Casting SIG <i>Tom Moore</i>	Novice SIG <i>Rich Pichler</i>

About the Upcoming October 8 Meeting

General meetings are usually held on the second Saturday of each month at 12:00 noon in the meeting rooms of the Parker Williams County Library, 10851 Scarsdale Boulevard, Houston, TX 77089. The meeting location has been confirmed through December. This month's meeting will be held on October 8th. Visit our [website](#) for up-to-the-minute details.

Bill Swann will talk about his home solar panel array.

Recap of the September 10 General Meeting

By Martin Kennedy, with photos by Dick Kostelnicek and Martin Kennedy



Twenty-five members and one guest – Ken Sheldon - attended the 12:00 noon meeting at the Parker Williams County Library. President *Vance Burns* led the meeting.

Mike Hancock moved that we relocate meetings to more central location. Mike will investigate potential locations and report back at the next meeting.

Members were encouraged to enter their biographical information on the [HMSC biography web page](#).

If you have an idea for a meeting topic, or if you know someone who could make a presentation, please contact [John Hoff](#).

Presentation



This month's presentation was by *Randy Slane* with [Drago Supply](#) in LaPorte, Tx. Drago sells a variety of industrial tools and supplies and has about \$100 million per year in sales. Randy specializes in abrasives, with 3M as his favorite vendor. 3M started its business producing sandpaper and *Scotch Tape*. Another well-known invention is *Post It Notes*.

Randy's favorite product line from 3M is the recently introduced [Cubitron II](#) abrasive. Cubitron II is yet another innovative product from 3M, and there is nothing else like it on the abrasives market. To build the product, 3M started with ceramic abrasives, made into small triangles. They are magnetized during production to

allow them all to be installed point up. This produces a very uniform cutting surface which will remove material at 3X speed compared to conventional abrasive grits. It also leaves a nicer finish because the scratch size is uniform. As a result, a 36 grit finish looks like a 60 grit finish using conventional abrasives, such as aluminum oxide, aluminum zirconium, conventional ceramics or garnet.



A Cubitron II disk replaces a typical \$40 cup disk at much lower cost – only about \$3. An added benefit is that the weight is much less than regular grinding wheels. The lower weight, combined with being much easier to control, allows finishes not possible with conventional disks.

The same ceramic material, but not shaped with the points all up, is available in conventional cut-off wheels (Green Corps), and sanding belts. The 3M product is relatively expensive, but life cycle costs are much better since it is faster cutting and longer lasting.

Randy was asked what type of abrasive to use on aluminum. Although he sells special wheels, he recommended using the cheapest thing you can get, since the wheels need to wear quickly to prevent loading up with aluminum.

Another product Randy represents is 3M flap wheels. The product started out being used to produce a popular belt and was then made into a flap wheel. Cubitron I flap wheels are available, but Randy recommends the Cubitron II wheel instead, and it's cheaper. Flap Wheels can be used on thinner steel to finish off welds. They're great on contours and are also used by metal artists.

Randy showed a new Scotch-Brite radial bristle brush made of plastic with cubitron minerals. This brush can be used to replace wire wheel. It's much better from a safety standpoint since it doesn't release wires. There's also a new light grinding and blending conventional Scotch-Brite wheel available that he likes.

For cutting carbide, Randy thought that 3M Trizact might work, although he hadn't tried it. Trizact is cheaper than diamond wheels.

Moving to another type of product from 3M, Randy showed VHB (very high bond) tape. This is a very strong two sided tape that has been around for 35 years. Buildings have been built with it. It's

extremely difficult to pull it apart. Randy passed around some samples with conventional two sided foam tape and VHB. None of our members could pull the VHB apart. The tape is great for assembly of metal items. It's not as strong as welds, but better than rivets over similar areas. Horse trailers and signs are typical applications. The tape also makes water tight seals.

Randy offered to set up a group account for the HMSC at Drago that would let us buy products by mail order at a volume discount.

Show and Tell

Martin Kennedy – showed an alcohol lamp that he made as part of a Stirling engine that he is building. The body of the lamp had a complicated 3D shape, and was machined on his 4-axis mill (right photo).

Joe Williams - Recounted how he had installed a Centroid control system on his Tree CNC Mill. The original control system was obsolete, and couldn't be repaired despite the efforts of multiple people after he started getting control errors.

David Ballinger – Presented a book called "Fine Shotguns" to Joe Scott for his help with gun questions.

Joe Scott – A few months back, Joe spoke about 16-inch naval rifles. This month, he showed a picture he took at the Washington Navy Yard of 25-inch thick Japanese ship's gun armor plate captured after WWII that was test shot with the 16-inch naval rifle (right photo).

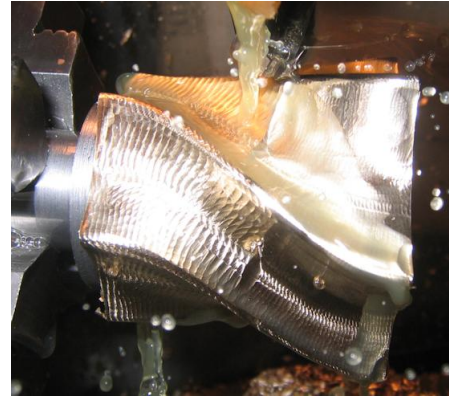

Joe recently acquired a Kalamazoo band saw. While reviewing a parts list, he noticed that inexpensive brushes were available for the saw to keep the blade clean and free from debris which makes the blade last longer.

He also showed a fixture (left photo) that he built with cam operated lever to allow quick and accurate positioning of parts during a milling run.



Ray Tompson – demonstrated a noncontact RPM meter that he recently acquired (left photo).

Gary Toll (not shown) - donated several books on lubrication to the HMSC library. He showed several Harry Potter style magic wands for kids (right photo). However, He was unable to source a *Phoenix Feather* or *Unicorn Hair* for

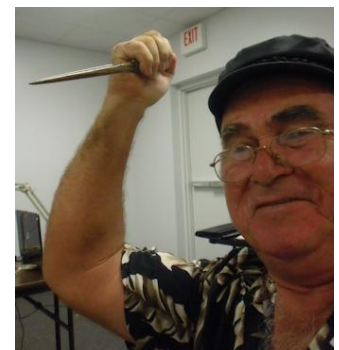

the center. A fellow club member demonstrated their use (right photo). Gary passed around a variable speed motor from his air conditioner that he was trying to fix.

Problems and Solutions

Dick Kostelnicek – found a solution for the florescent lights in his shop that always work fine in the winter but won't reliably start during the humid summer. He had tried several solutions proposed by club members and others found on the internet. The only thing that consistently corrected the problem was replacing the florescent tubes. Dick knew that the higher humidity in the summer was somehow responsible for them not starting. His solution was to wipe down the tubes with ammonia water to remove a film of oil and dust particles, possibly even mold. After doing this, they all worked great. Joe Scott said that he had a similar problem that was caused by the sockets having a bronze spring clip that corroded and did not make good connection with the wires.

Joe Scott – Made sun shades out of his window screens from a 92% opaque fabric he got in the home improvement store garden department. He put it into his screen frames using the next size smaller elastic screen spline.

Ken Sheldon asked about how he could move a vertical mill. It was suggested that he call wrecker companies that use a rollback deck wrecker. The price is around \$400. He should make sure that the company has experience moving heavy equipment. Once in his shop, he could use 3/4 or 1/2-inch heavy wall water pipe as rollers, and a 6-foot pry bar to move the equipment around. Larger pipes were not recommended, since they would raise the machine too high and make it unstable.

Novice SIG Activities

Martin Kennedy demonstrated how to use several measurement tools, including vernier, dial and digital calipers, vernier and digital micrometers, depth and inside micrometers, feeler gauges, and angle gauges.



Making a Dovetail Milling Bit

By Martin Kennedy

I needed to cut a dovetail in a piece of ½-inch plate for a dial indicator holder that I was making for my Aloris style AXA toolpost. I didn't want to buy an expensive 60-degree milling cutter for just one use, so I decided to make my own cutter. This turned out to be a simple project.

I turned a short mild steel shaft on my lathe with a 60-degree flare on the end. The 2 ½-inch long shaft was ½-inch in diameter, with a 7/8-inch diameter flare. I cut a flat spot in the flare with my mill to hold a small carbide insert. Note that the cut is at a 30-degree angle to the shaft's axis in order to hold the base of the 60-degree carbide insert parallel to the shaft's end. I used a TCMT 21.51 insert. I drilled and tapped a hole for the insert holding screw, and cut a Weldon flat on the shank to finish the cutter.

You may notice in the picture below that there are some zigzag marks on the tool's shank. They were caused by twisting of the relatively soft shaft in a hardened tool holder.

I made the tool such that the front face of the carbide insert was on the centerline of the tool, as shown in the photo below. I got it slightly crooked, but it worked anyway. The most important consideration is that the backside of the carbide chip does not drag on the cut. The carbide insert has enough relief that this was not a problem.



I made the cut in my indicator holder with the tool taking successively larger cuts and at a slow feed rate. I wouldn't recommend this tool for production use, but for the single use that I had for it, it worked just fine and it was easy to make. You may notice some small landings at the base of the cut (right photo below). I made it like this to match the manufacture of commercial indicator holders that I have. It may or may not be necessary.

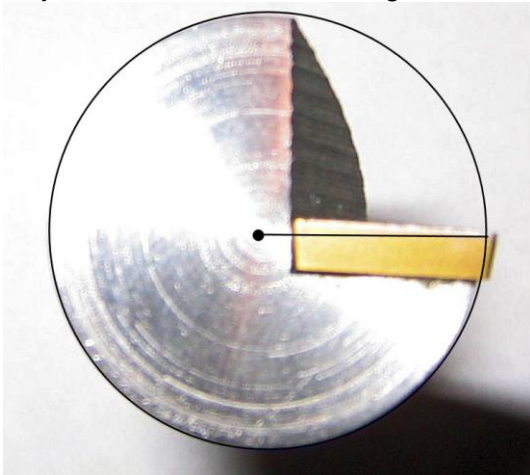

Milling Machine Right Angle Adapter

By Dick Kostelnicek

My vertical mill is a MILRITE. Once in a while I need it to perform like a horizontal mill. A right angle adapter is the answer. The mill has a R8 spindle bore. So, in order to use my existing tooling, I wanted the right angle adapter to also have a R8 bore.

The adapters collar slips over and chinces around the mill's vertical quill, which is 3.25-inches in diameter. Other mills, such as a Bridgeport, have a 3.375-inch quill. There is enough wall thickness in the XXH pipe, that is used to make the collar, to accommodate the wider Bridgeport quill.

Miter and pinion gears reduce the spindle speed by one-half. You may prefer to use spiral bevel gears to quiet the gearbox noise.

The picture at the right shows the adapter driving a large metal cutting saw blade. Sawing provides an means to cut plate right on the mill.

The gearbox's sides, front, and back plates were assembled with silicon calk (RTV) and the unit is partially filled with 90 weight transmission oil.

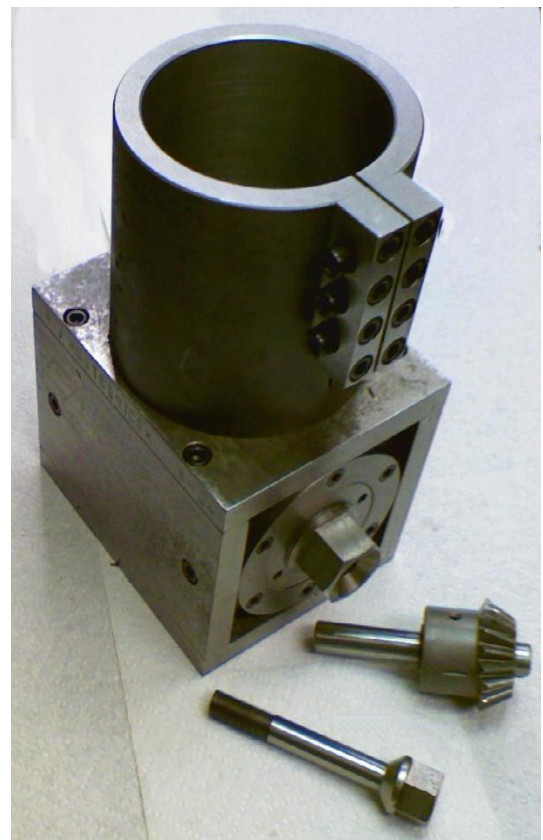
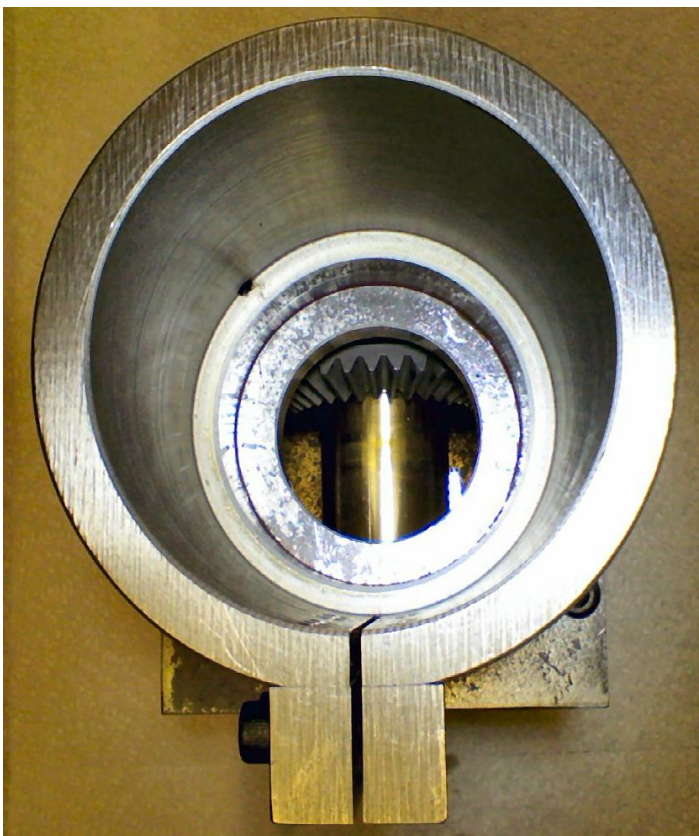
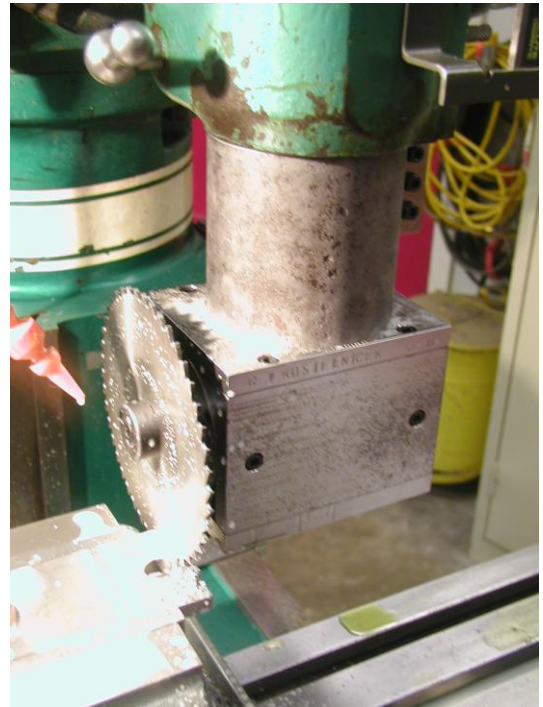

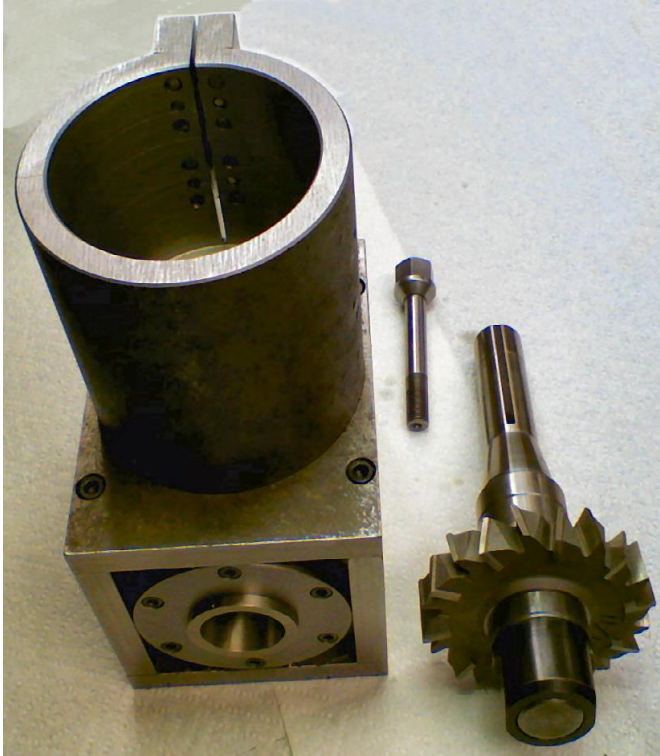

The left photo on the previous page shows a view looking down into the adapter's collar. The large bevel gear that drives the adapter's spindle is seen through the hole in the top of the gearbox.

The pinion gear is mounted on a 1/2-inch shaft (bottom above right photo). The shaft is driven by a 1/2-inch collet held in the mill's vertical spindle. During mounting, the adapter's collar is slid up over the mill's quill and cinched by the screws in the vertical collar lips (above right photo).

The gears are engaged by loosening the mill's draw bar, thereby allowing the pinion gear and shaft to drop down and make contact with the adapter's horizontal miter gear. The mill's drawbar is then retightened, which pulls the pinion slightly upwards. This separation provides for the gear's running clearance.

The left photo shows a horizontal milling cutter mounted on a R8 arbor next to the adapter. The arbor is inserted into the front of the adapter's

hollow R8 spindle and is held in place by the short drawbar shown near the rear of the adapter.

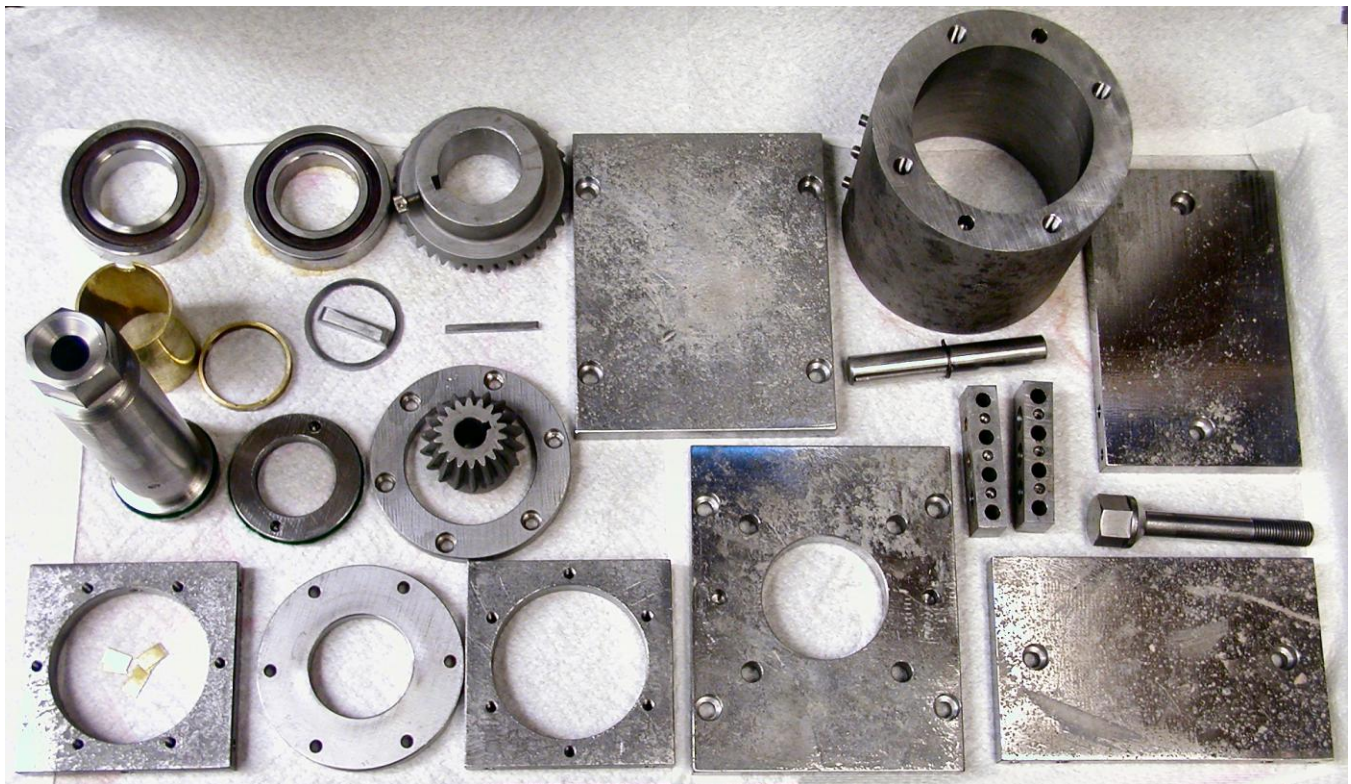

The above picture shows the unassembled parts of the right angle adapter. A bill of materials follows.

Milling Machine Right Angle Adapter - Bill of Material

Plates

2 – ½ x 4 1/4 x 5 1/4
2 – ½ x 3 ¼ x 5 1/4
2 – ½ x 3 ¼ x 3 1/4
2 – ½ x ¾ x 2 3/8
2 – 3/8 x 3 ¼ x 3 ¼
1 – 5/16 x 2 1/8 x 2 1/8

Drawing 05 - Bottom, 07 – Top
Drawing 06 - Side
Drawing 08 - End
Drawing 15 - Collar Lip
Drawing 09 - Front Retainer, Drawing 10 – Rear Retainer
Drawing 11 - Spindle Nut

Round Bars

1 - 1 5/8 D x 6 5/16
1 - ½ D x 3 5/16
1 - 7/8 D x 3 5/8

Drawing 01- Spindle
Drawing 14 - Pinion Shaft
Drawing 16 - Draw Bar

Pipe

1 – 4 OD x 0.636 Wall x 3 7/8
3 ½ XXH pipe

Drawing 13 - Collar

1 – 1 5/8 OD x 1 3/8 ID x 1 7/8
1 – 1 5/8 OD x 1 3/8 ID x 5/16

Drawing 12 - Spindle Spacer (long)
Drawing 12 - Spindle Spacer (short)

Dowel Pin

4 – 3/16 x ½
16 – 3/16 x 5/8
2 – ¼ x 5/8

Socket Head Cap Screws

4 – 5/16 – 18 x 1
4 – ¼-20 x 5/8 SHCS
8 – ¼-20 x ¾ SHCS
12 – 10-32 x ¾ SHCS
1 – 8-32 x 5/16 Set Screw

Gear

1 - Boston Gear L152BY-G-L
1 - Boston Gear L152BY-P-L

Drawing 03 - Gear
Drawing 04 - Pinion

Square Keys

1 - 1/8 Square 1 3/8 Long
1 - ¼ Square 1 1/4 Long

Drawing 02 – Square Key
Drawing 02 – Square Key

Bearings

2 – Angular Contact Ball 9107 – 35 x 63 x 14 mm
Alternative = Tapered Roller 32007 – 35 x 62 x 18 mm

External Retaining Ring

1 – for ½ in. shaft

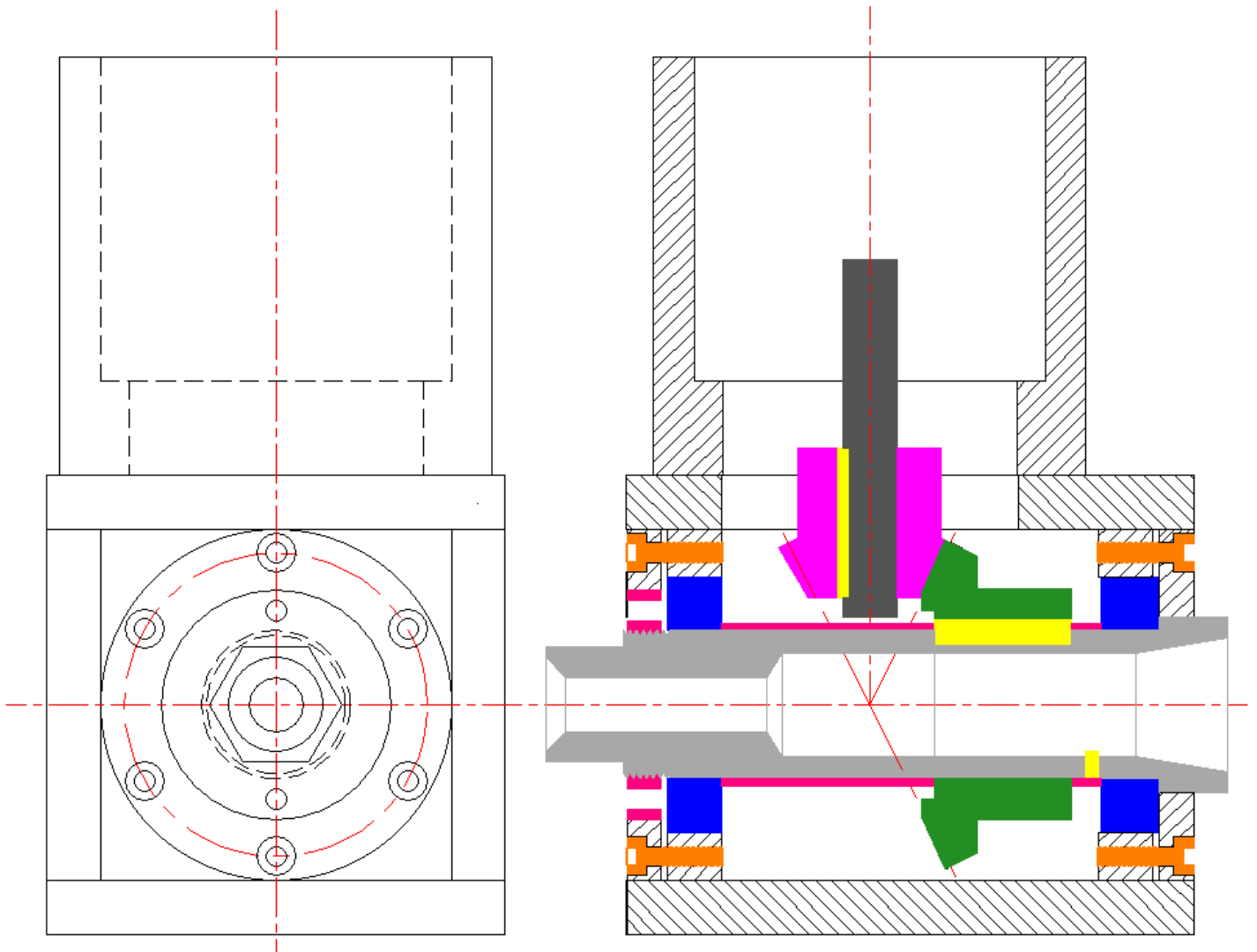

2 - Housing Mill Right Angle Adapter

Copyright (C) R. J. Kostelnicek 2011

Drawing 14 - Pinion Shaft

Square Keys

Drawing 01 - Spindle

Bearings

Drawing 04 - Pinion

Drawing 03 - Gear

Socket Head Cap Screws

Drawing 11 - Spindle Nut
 Drawing 12 - Spindle Spacers

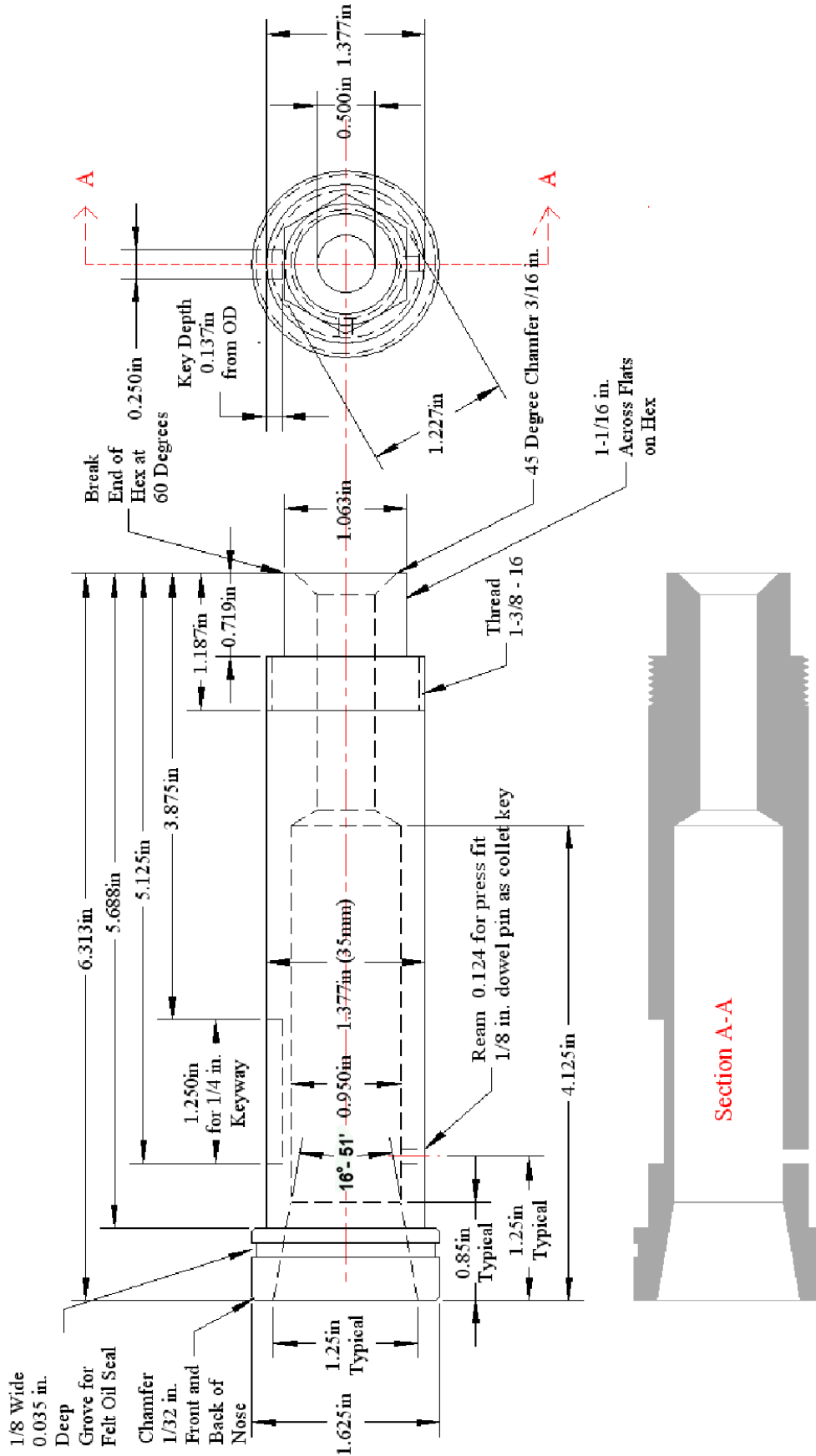

1 - Spindle - Mill Right Angle Adapter

Copyright (C) R. J. Kostelnicek 2011

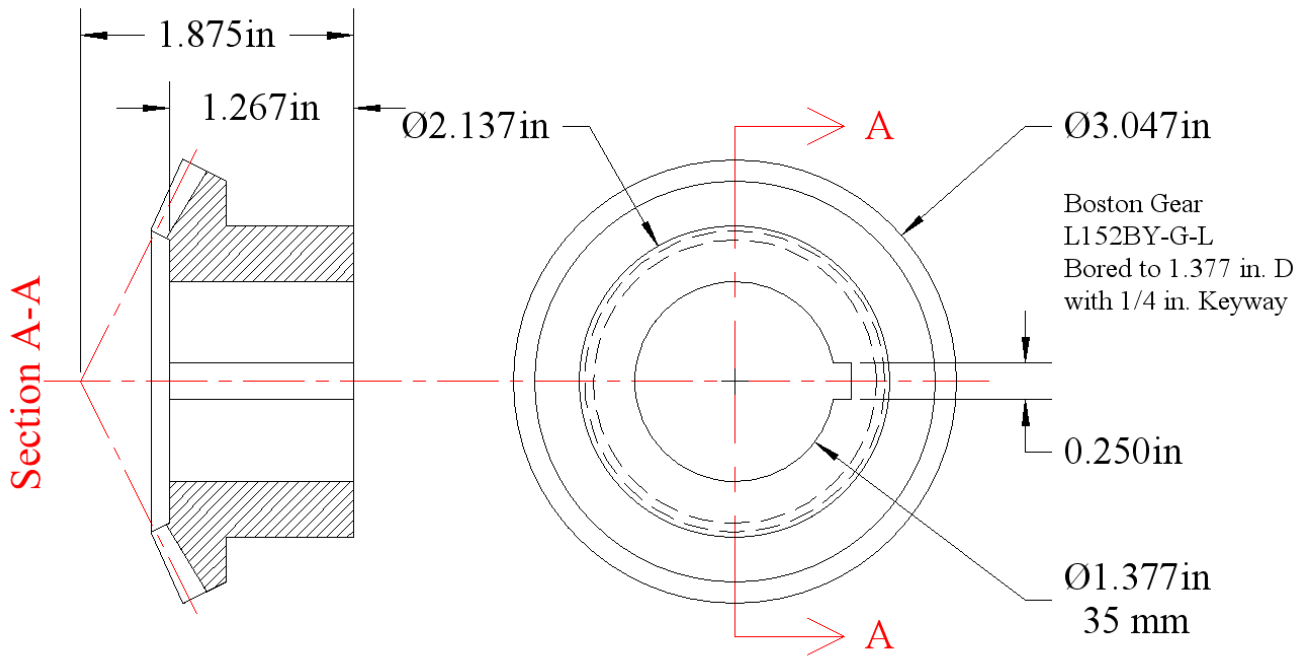

3 - Gear - Mill Right Angle Adapter

Copyright (C) R. J. Kostelnicek 2011

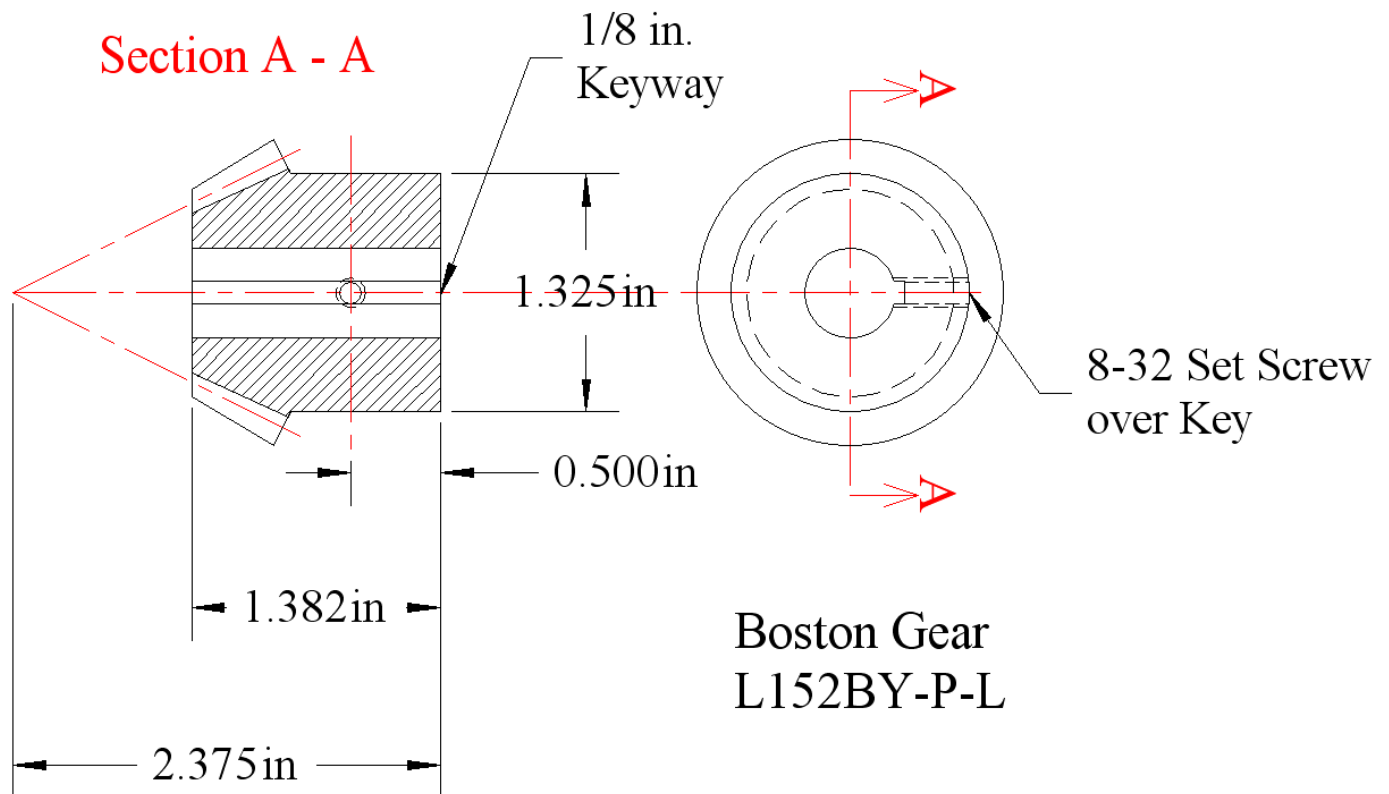

4 - Pinion - Mill Right Angle Adapter

Copyright (C) R. J. Kostelnicek 2011

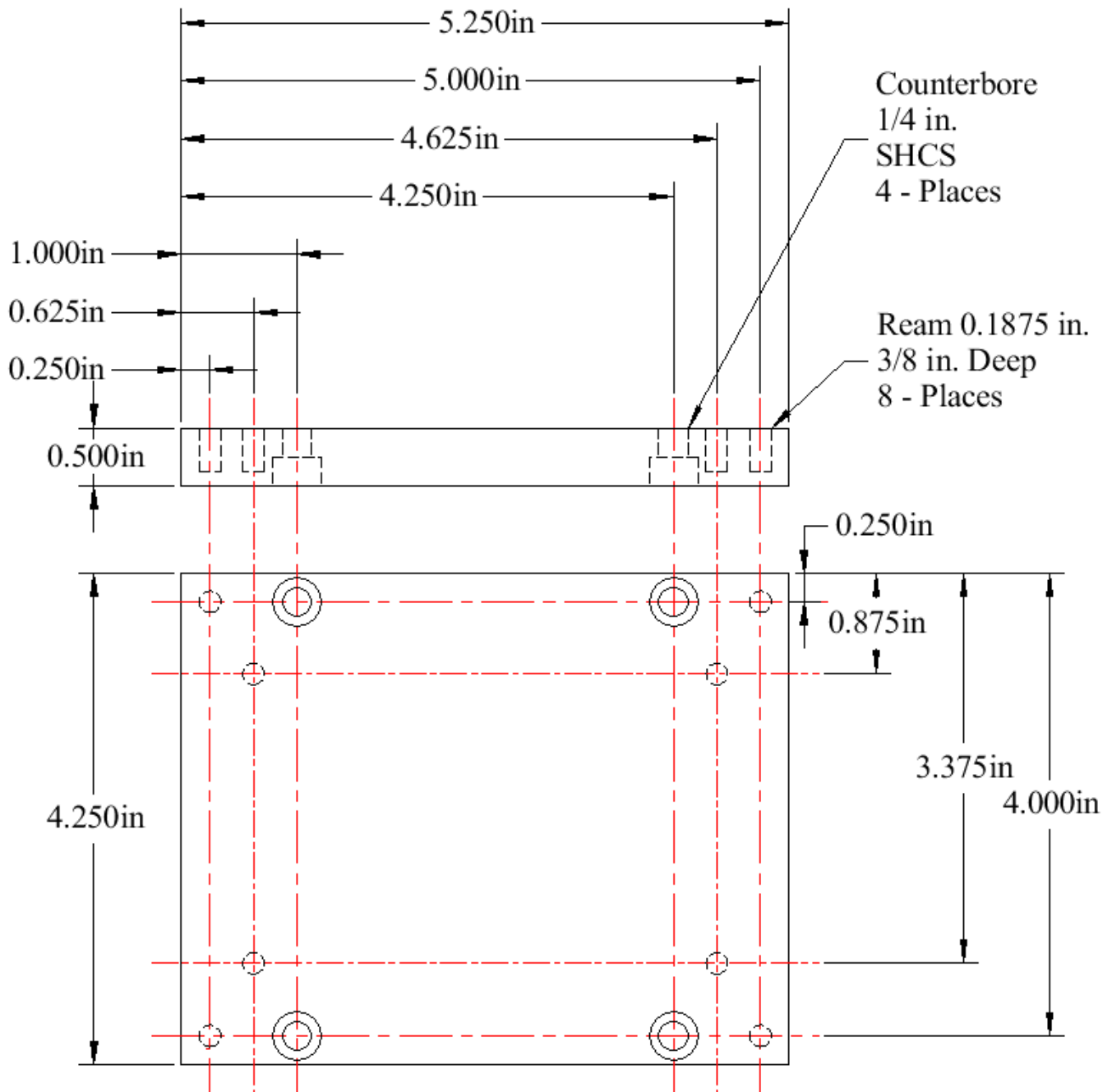

5 - Bottom - Mill Right Angle Adapter

Copyright (C) R. J. Kostelnicek 2011

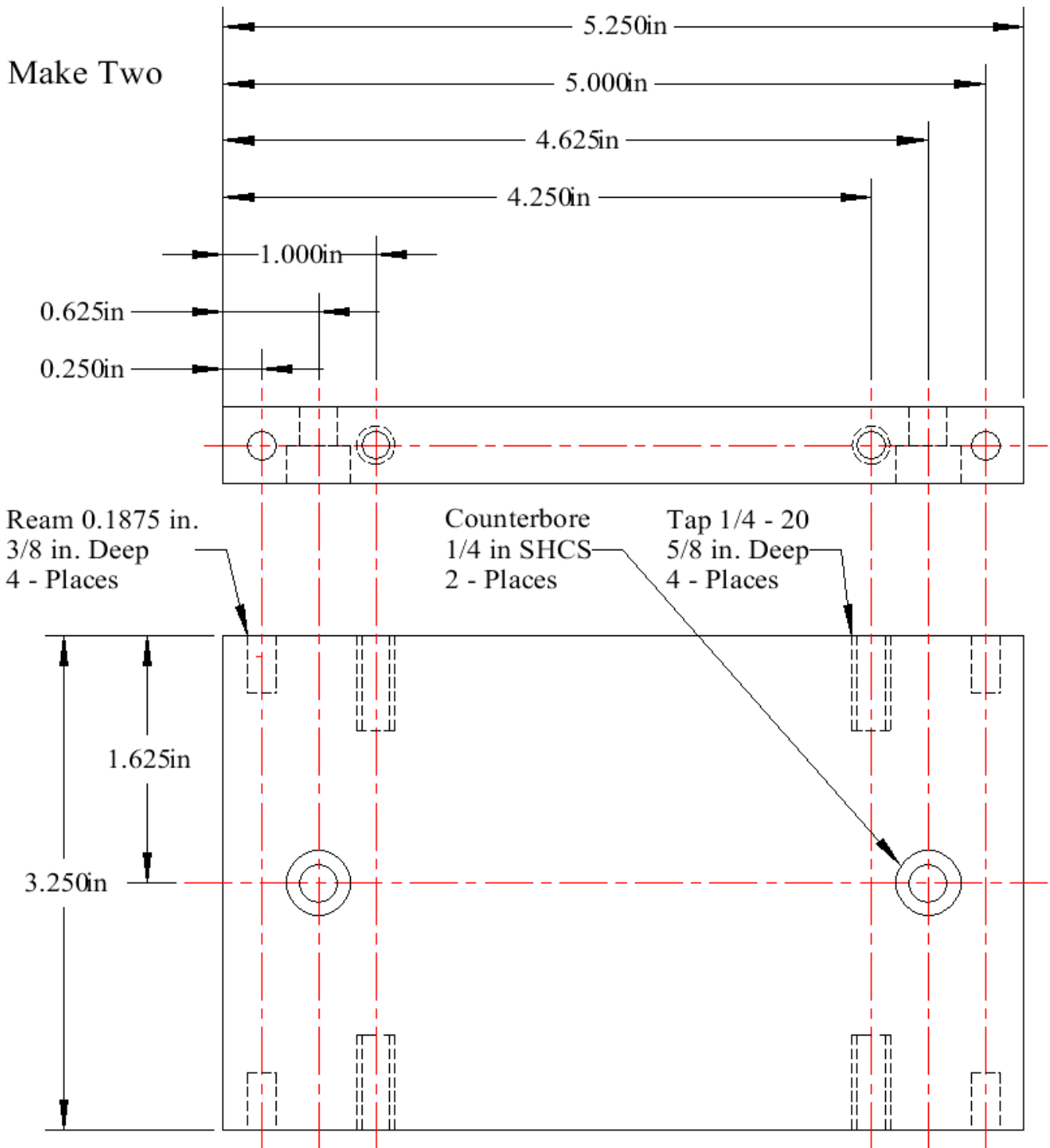

6 - Side - Mill Right Angle Adapter

Copyright (C) R. J. Kostelnicek 2011

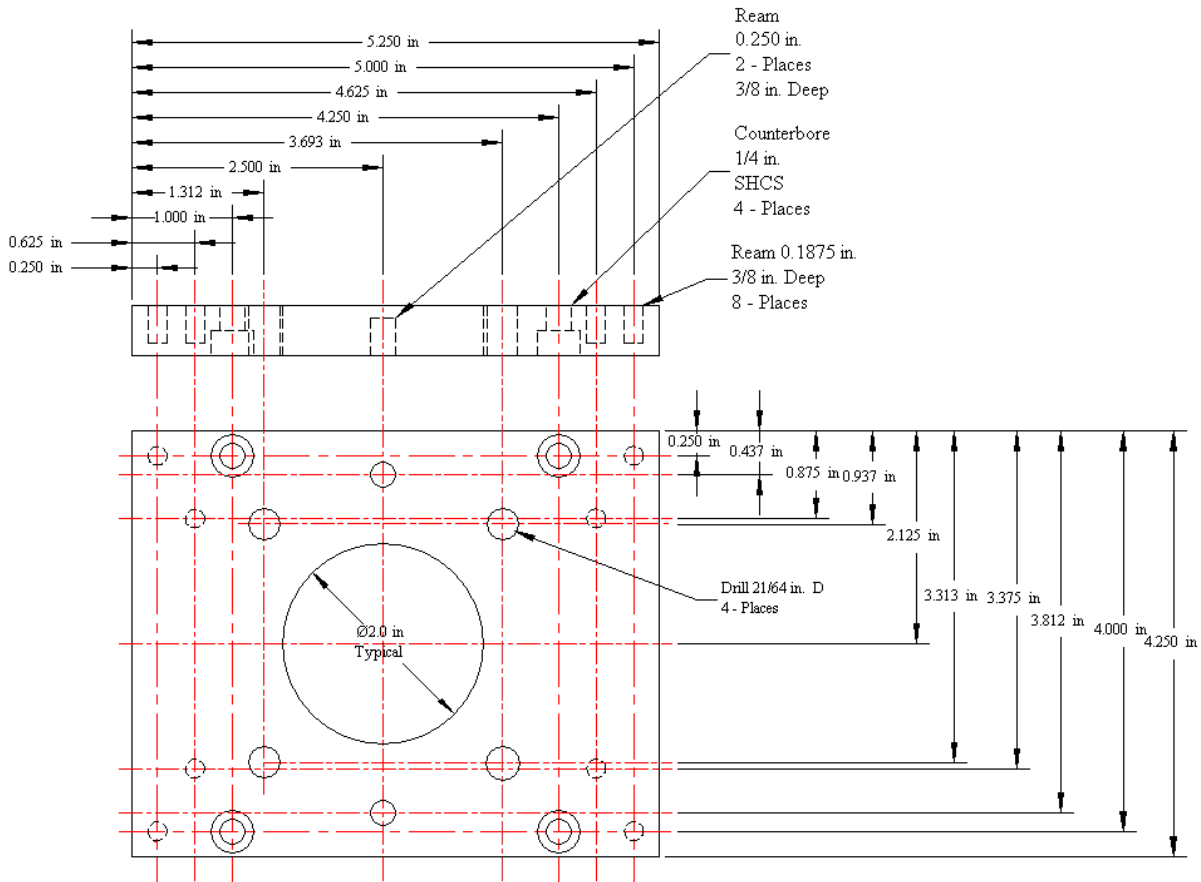

7 - Top- Mill Right Angle Adapter

Copyright (C) R. J. Kostelnicek 2011

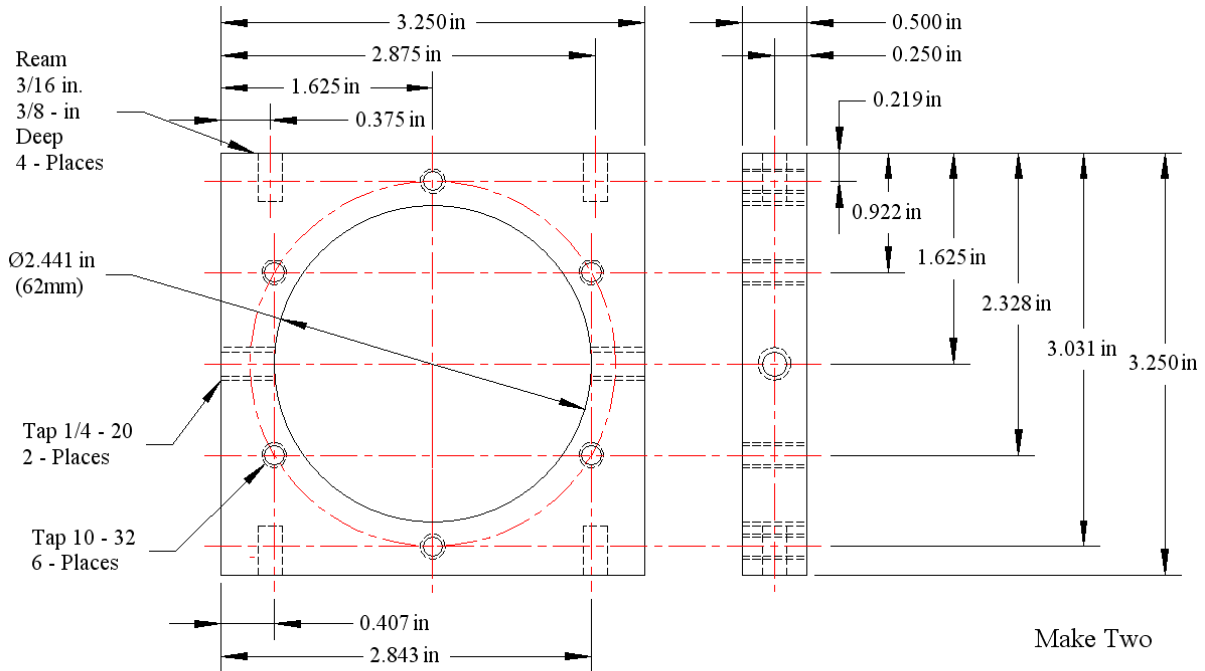

8 - End - Mill Right Angle Adapter

Copyright (C) R. J. Kostelnicek 2011

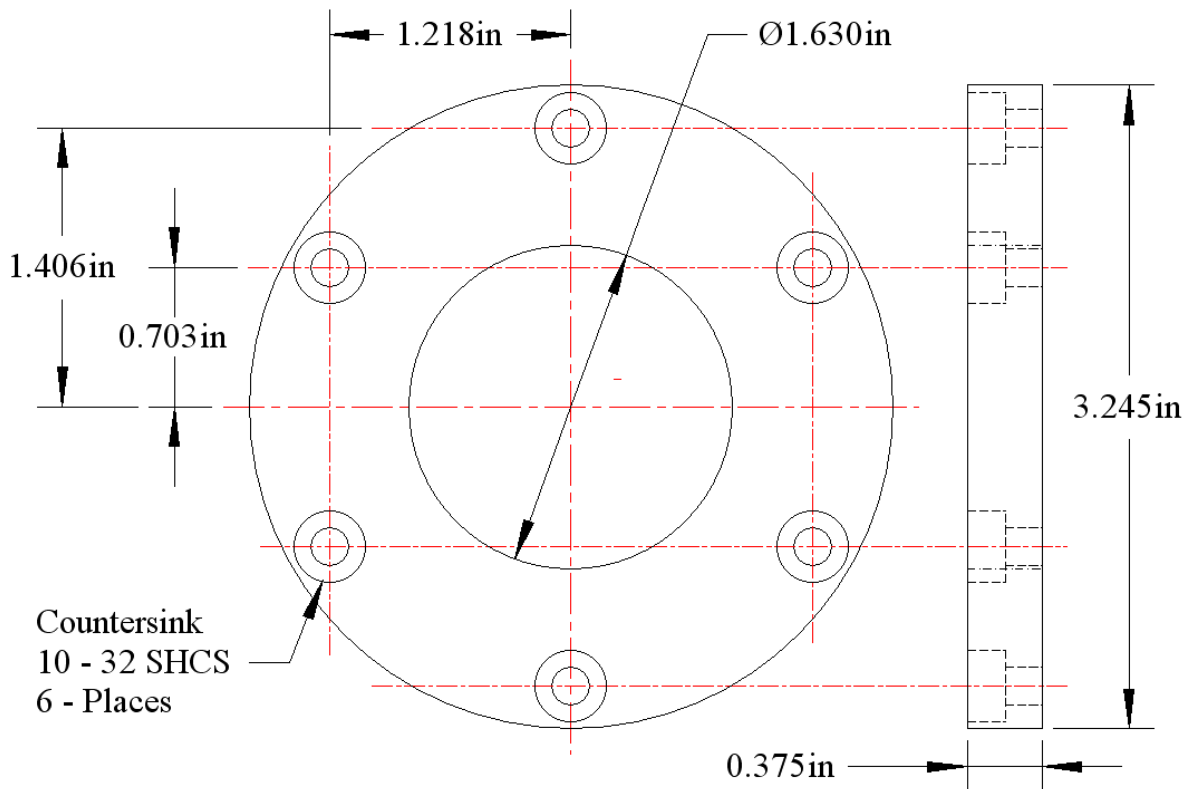

9 - Front Retainer - Mill Right Angle Adapter

Copyright (C) R. J. Kostelnicek 2011

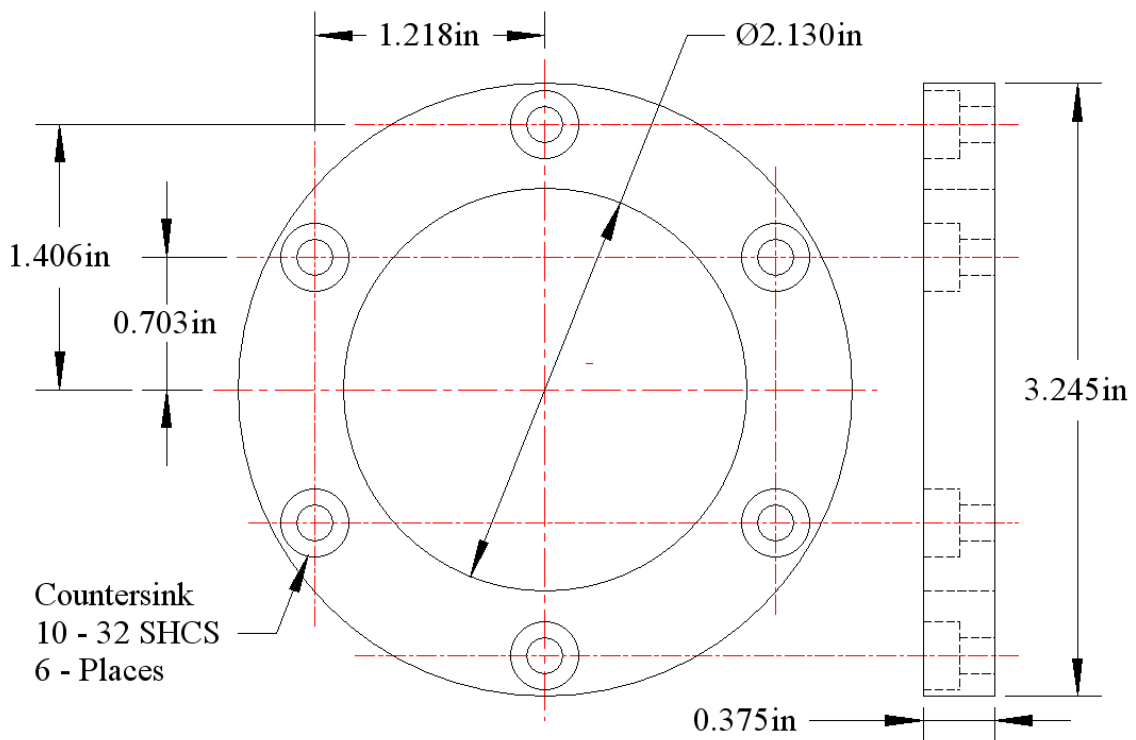

10 - Rear Retainer - Mill Right Angle Adapter

Copyright (C) R. J. Kostelnicek 2011

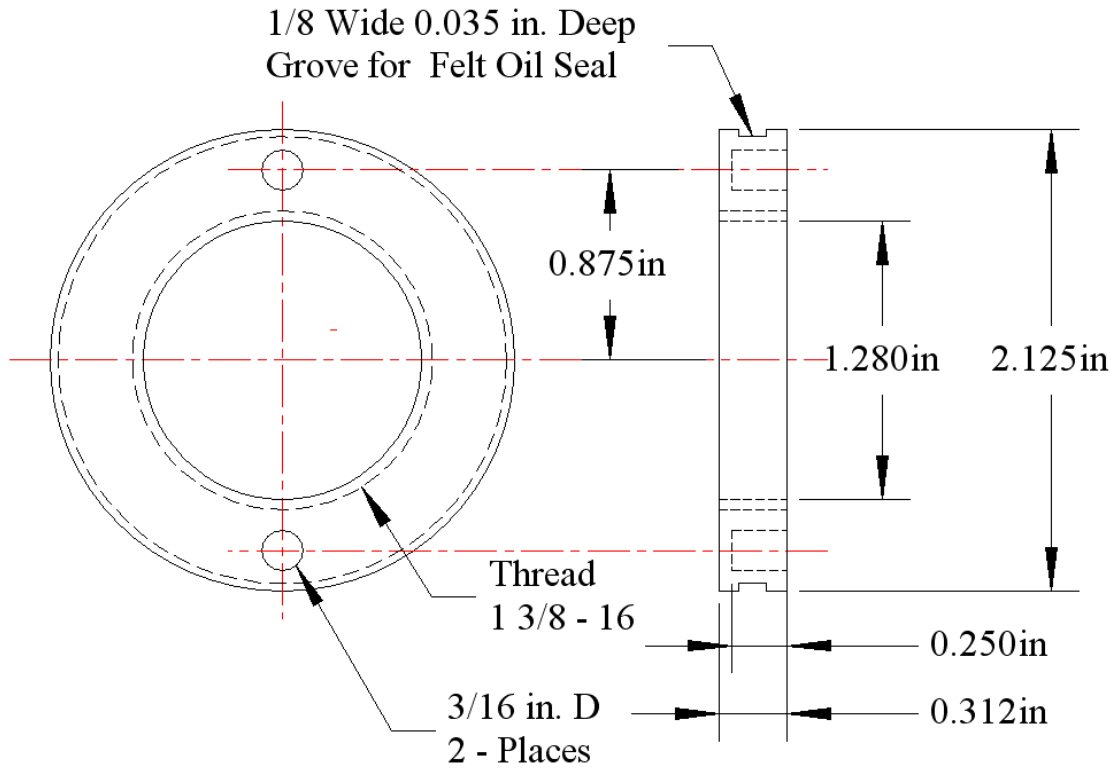

11 - Spindle Nut - Mill Right Angle Adapter

Copyright (C) R. J. Kostelnicek 2011

Make two

for Bearing 9107.... 2.188 and 0.203 in. Long

for Bearing 3207.... 2.031 and 0.046 in. Long

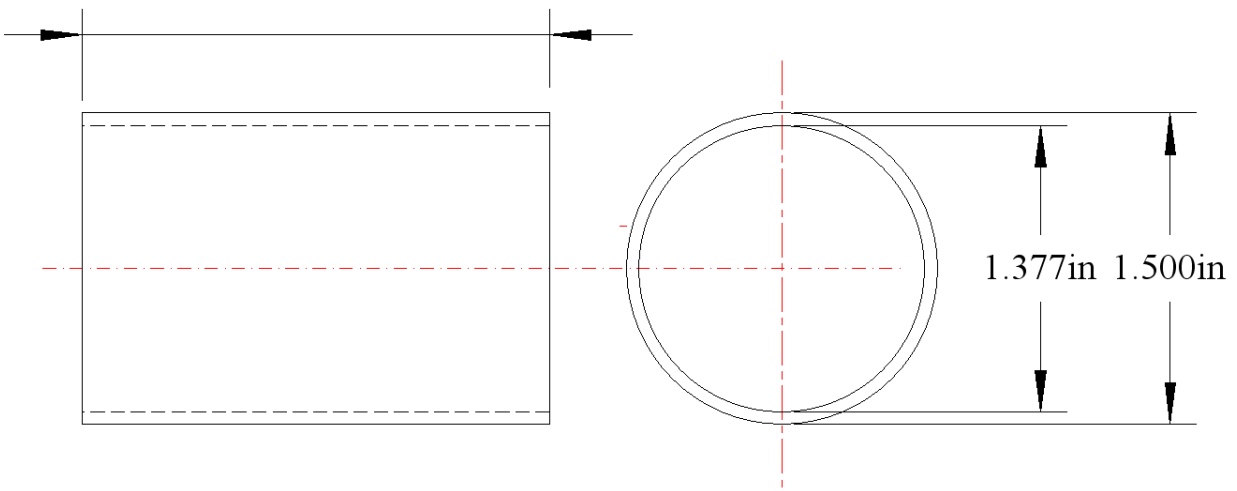

12 - Spindle Spacer- Mill Right Angle Adapter

Copyright (C) R. J. Kostelnicek 2011

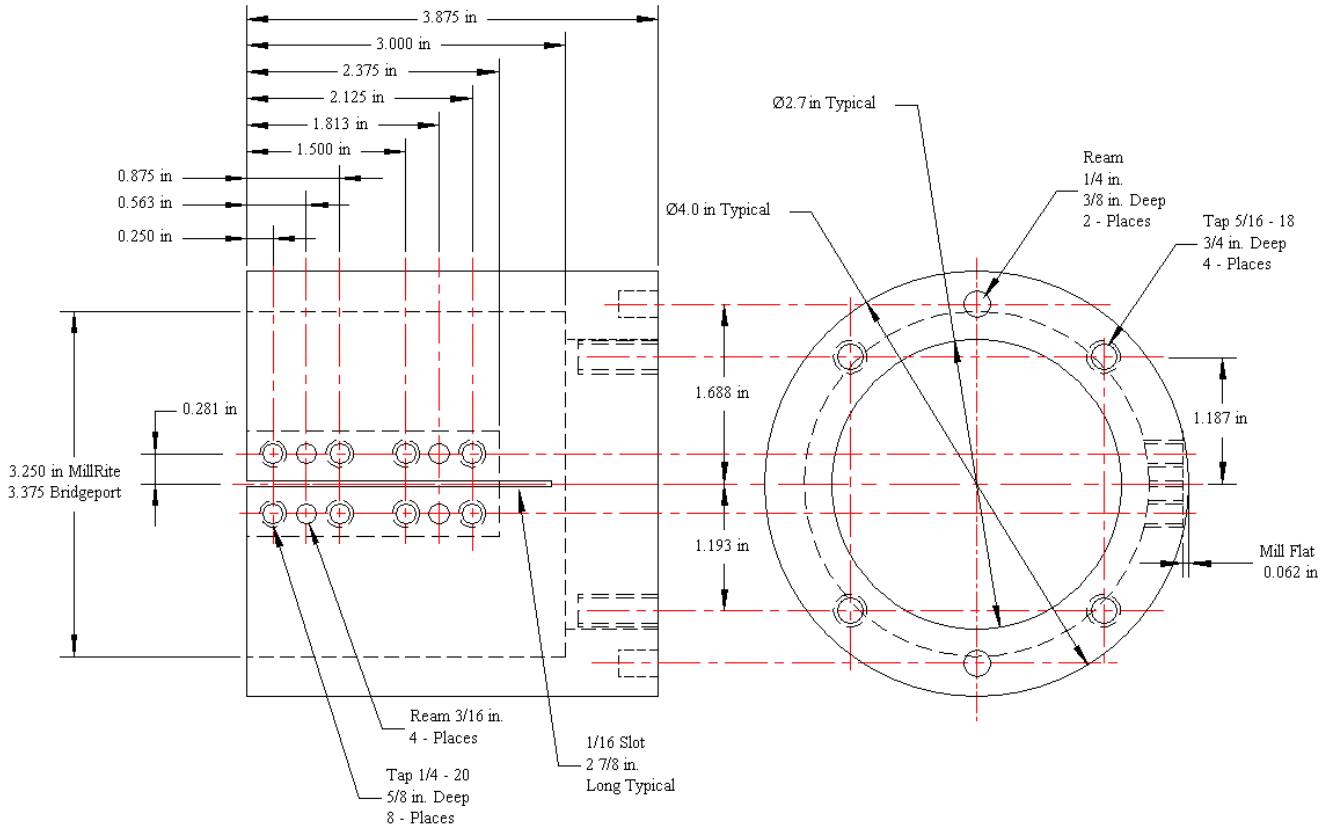

13 - Collar Mill Right Angle Adapter

Copyright (C) R. J. Kostelnicek 2011

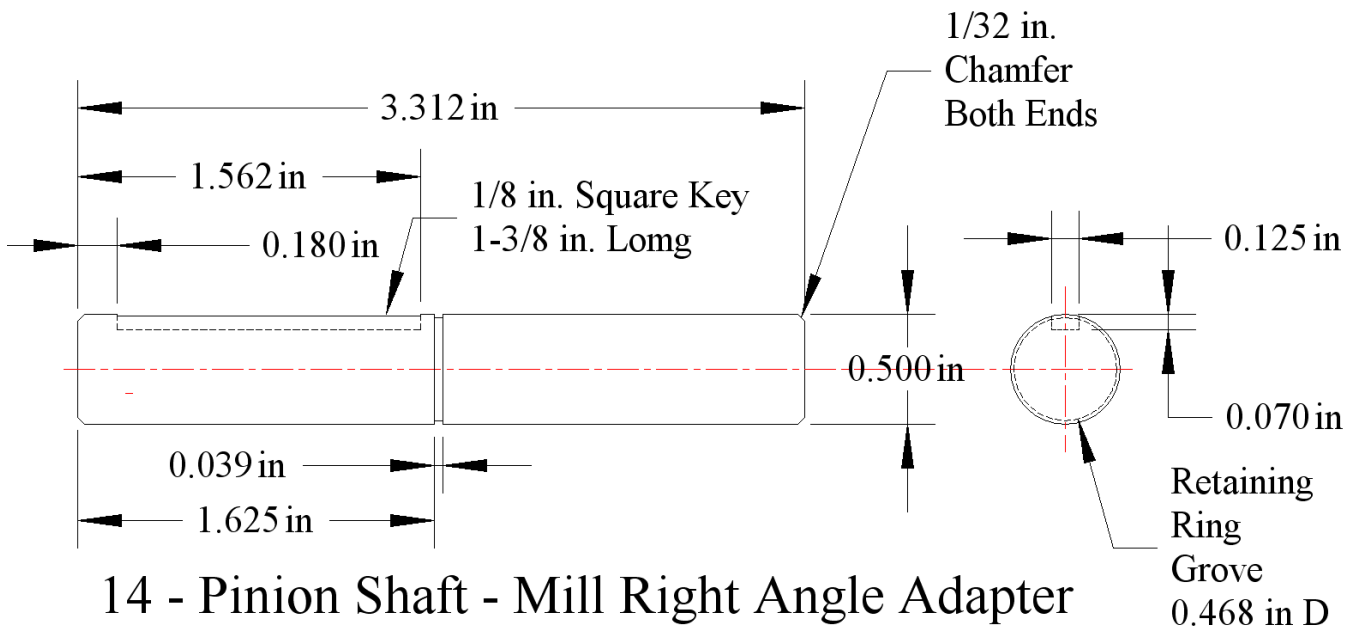

14 - Pinion Shaft - Mill Right Angle Adapter

Copyright (C) R. J. Kostelnicek 2011

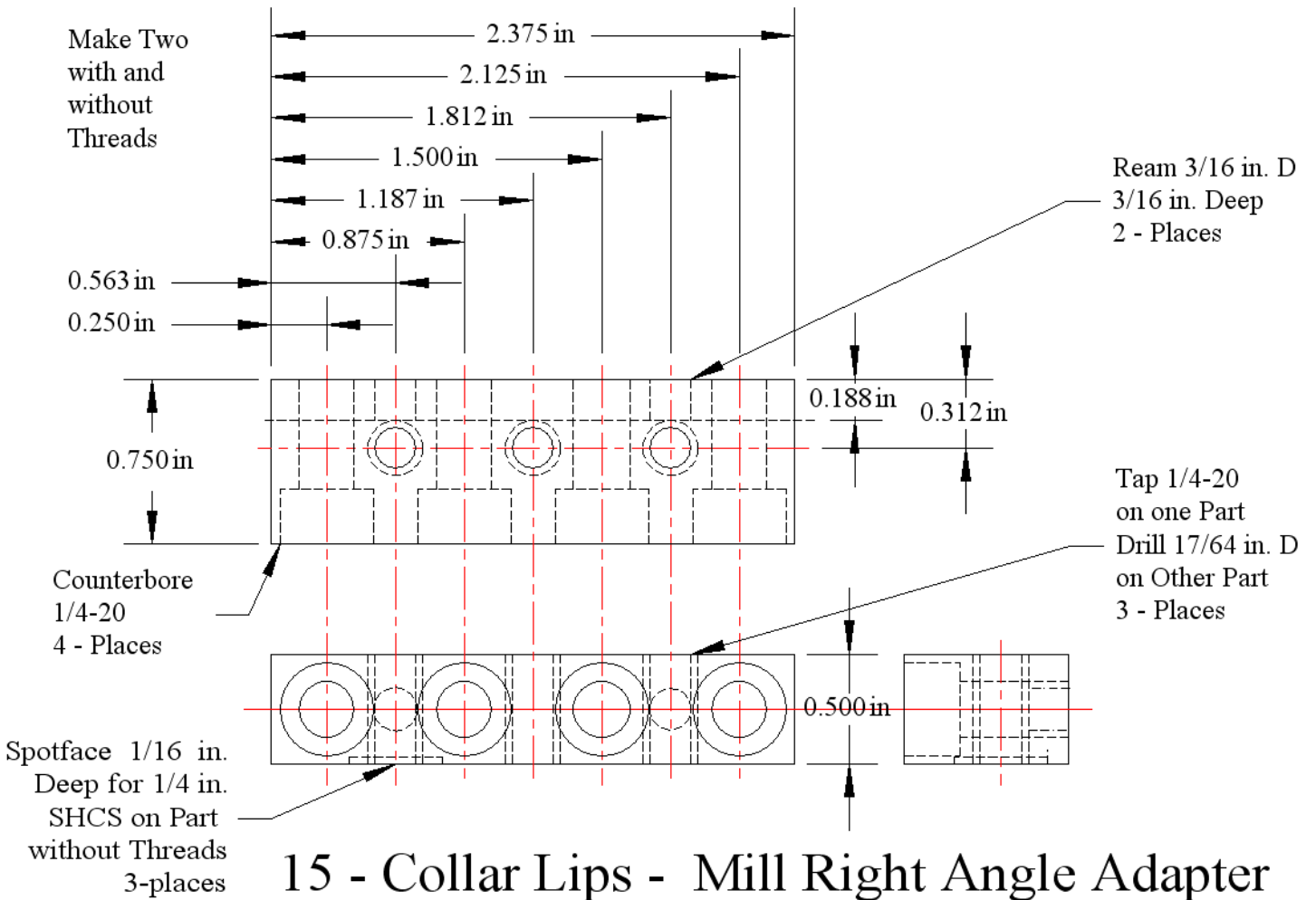

Copyright (C) R. J. Kostelnicek 2011

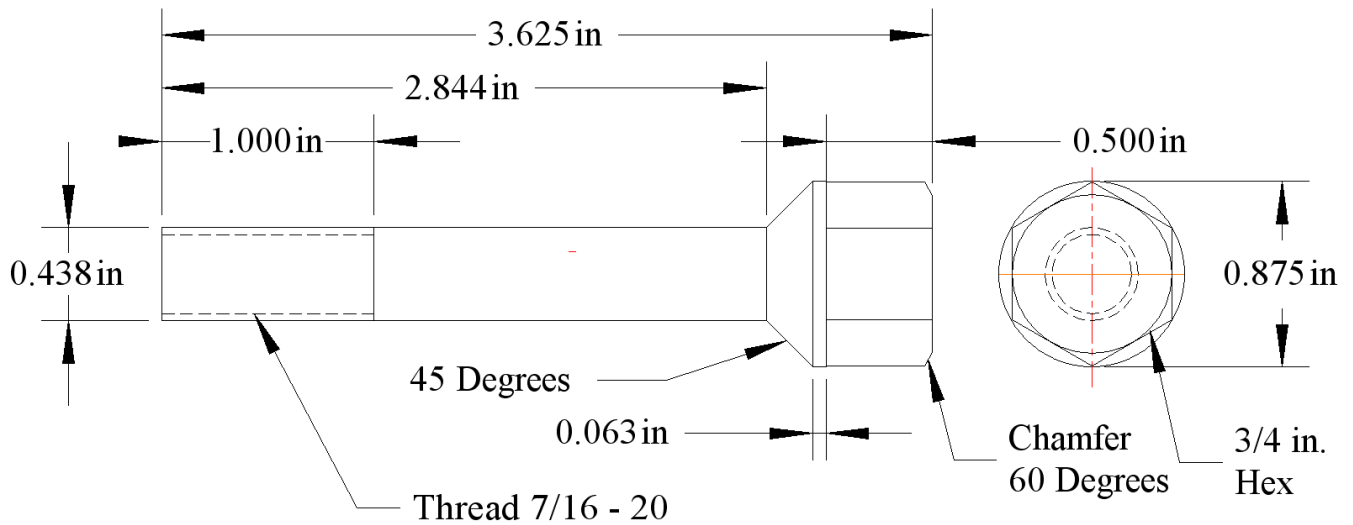

Copyright (C) R. J. Kostelnicek 2004