

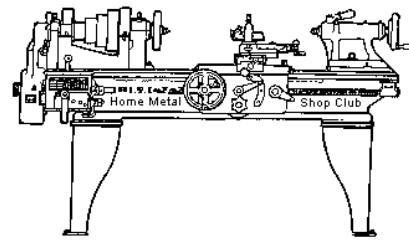

**June 2013**  
Newsletter

Volume 18 - Number 6



<http://www.homemetalshopclub.org/>

The Home Metal Shop Club has brought together metal workers from all over the Southeast Texas area since its founding by John Korman in 1996.

Our members' interests include Model Engineering, Casting, Blacksmithing, Gunsmithing, Sheet Metal Fabrication, Robotics, CNC, Welding, Metal Art, and others. Members enjoy getting together and talking about their craft and shops. Shops range from full machine shops to those limited to a bench vise and hacksaw.

If you like to make things, run metal working machines, or just talk about tools, this is your place. Meetings generally consist of *general announcements*, an *extended presentation* with Q&A, a *safety moment*, *show and tell* where attendees share their work and experiences, and *problems and solutions* where attendees can get answers to their questions or describe how they approached a problem. Meetings end with *free discussion* and a *novice group* activity, where metal working techniques are demonstrated on a small lathe, grinders, and other metal shop equipment.

President  
*Vance Burns*

Vice President  
*Norm Berls*

Secretary  
*Joe Sybille*

Treasurer  
*Emmett Carstens*

Librarian  
*Dan Harper*

Webmaster/Editor  
*Dick Kostelnicek*

Photographer  
*Jan Rowland*

CNC SIG  
*Dennis Cranston*

Casting SIG  
*Tom Moore*

Novice SIG  
*Rich Pichler*

This newsletter is available as an electronic subscription from most any page of our [website](#). We currently have over 220 subscribers located all over the world.

## About the Upcoming July 13 Meeting

General meetings are usually held on the second Saturday of each month at 12:00 noon at the [Jungman Library](#), located at the intersection of Westheimer Road and Augusta Drive (about one mile west of the Galleria shopping mall) in Houston, Texas.

The July presentation will be given by Dick Kostelnicek who will talk about MIG and Flux Core Welding - Theory - Machine Construction and Operation.

At the August Meeting Gene Rowan of [Rollformers of Texas](#) will talk about the art and practice of wire feed welding.

Visit our [website](#) for up-to-the-minute meeting details, date, location, and main presentation topic.

## General Announcements

[Videos of recent meetings](#) can be viewed on the HMSC website.

The HMSC has a large library of metal shop related books and videos available for members to check out at each meeting. The library is maintained and curated by [the club librarian](#), *Dan Harper*. These books can be quite expensive, and are not usually available at local public libraries. Access to the library is one of the many benefits of club membership.

We need more articles for the monthly newsletter! If you would like to write an article, or would like to discuss writing an article, please contact the [Webmaster](#), Dick Kostelnicek. In the September HMSC board meeting, the board elected to waive membership fees during the next membership renewal cycle for those providing newsletter articles.

Ideas for programs at our monthly meeting are always welcome. If you have an idea for a meeting topic, or if you know someone who could make a presentation, please contact the [Vice President](#), Norm Berls.

## Recap of the June 8 General Meeting

By Martin Kennedy, with photos by Jan Rowland



Twenty-one members and one guest, Matt VanHauten, attended the 12:00 noon meeting at the Jungman Library. President *Vance Burns* led the meeting.

Yearly officer elections were held. *Vance Burns* was re-elected as President. *Norm Berls* was elected Vice President, replacing *John Hoff* after many years of service. *Joe Sybille* was elected Secretary, replacing *Martin Kennedy* after many years of service. *Emmett Carstens* was re-elected as Treasurer, and *Dan Harper* was re-elected as Librarian.

A motion was made to consider having elections during the winter. Summer attendance at club meetings is generally lower than that in winter, and it was thought that a larger audience could yield additional club officer candidates. The motion was tabled pending discussion by the Officers.

A suggestion was made to consider having a welding SIG. Two club members volunteered to make a presentation on welding at next month's meeting.

The club has funds to purchase new books for the library. If you have suggestions, contact the [librarian](#), Dan Harper.

*Vance Burns* noted that internet site [archive.org](#) is a good place to find old publications, videos, books, and magazines.

## Safety Moment

*Vance Burns* recounted a recent incident where it was raining and thundering, and he was using an umbrella between the house to his wife's car. On his way, lightning hit a tree next to the driveway. The force of the impact knocked him down. He said, "The next time he'd leave his wife in the car until the thunder stopped."

*Rich Pichler* noted that it was a better idea to get an umbrella with a wooden rod, instead of a metal one.

*Tom Moore* needed to use a big 150+ pound vice on a swivel base for some milling operations. The large vice was on his pillar drill, and he needed to move it to his mill. He was concerned that he might injure his back if he tried to lift and move it. Instead, he used a rolling shop chair. He reasoned that if the chair could safely hold him, the vice was similar in weight and it could safely hold the vice. He adjusted the height of the drilling table to be the same as the chair, scooted the vice onto the chair, rolled it across his shop, adjusted the mill table, and scooted it on the mill without incident and without having to do any lifting.

## Presentation

Two videos were shown this month. The first was on [Monolithic Crankshaft Machining Operations](#). The video showed the use of a Bost lathe to machine a massive crankshaft.

The second was a series of [Fred Dibnah videos](#). The eight videos covered controlled demolition of brick chimneys using fire instead of explosives, restoration of old steam engines, maintenance on steam tractors, and some steam tractor shows.

## Show and Tell

*Joe Williams* explained how he had done some pipe thread milling. He was helping a friend get set up to do CNC pipe threading on 1,000 cast iron grill burners. Last month, he had asked if anyone knew if thread milling should be done from bottom to top, or top to bottom. Joe found some programs on the internet that generated G-code for a pipe thread tap, and all ran from bottom to top. The Excel based program he ended up using was from [Micro 100](#). It could generate code for one or two passes. He used the two pass code. It generates a spiral of increasing radius that cuts a tapered ½-inch pipe thread in 45 seconds. One advantage of using a thread mill, instead of a pipe tap, is that the thread mill avoids the problem of splitting the thin walled cast iron pipe during threading.



*Martin Kennedy* said that the new meeting location was just about 3 blocks from [Berings Hardware Store](#), and that they had a good collection of screws and fittings. He encouraged members to stop by after the meeting and have a look.

*Norm Berls*, left photo, brought in his Equatorial Mount Telescope. He spoke briefly on how to set it up for star gazing. The Equatorial Mount compensates for the rotation of the earth. His is manual,

although motorized versions are available. He noted that a telescope has much better optical characteristics than spotting scopes, and decided to adapt his telescope to spot for target shooting. He found that in use, his tripod vibrated, and he needed a solid base to account for the wind. He built a custom mount to use the telescope for spotting. The mount was brazed together, and has adjustment screws. He's found that the telescope spotting scope is good to 400 yards at 100x. At 600 yards, he can't see enough detail to make out a 7mm hole.

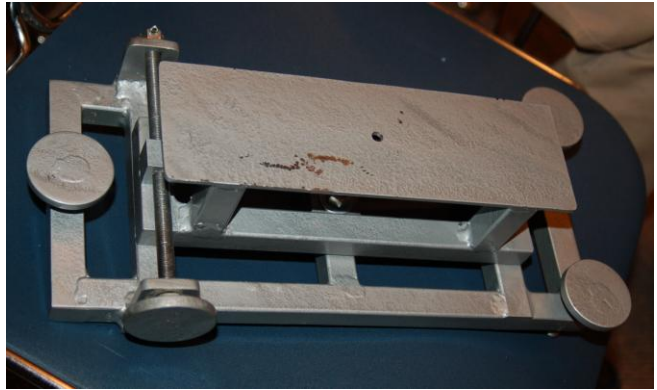

## Problems and Solutions / Ask the Blacksmith

A member has an induction cooktop. The cooktop requires that he uses magnetic stainless steel cooking vessels. Even with those, it has hot spots. He found that he can use cast iron pans with parchment paper between the pan and the top. He was thinking about cladding the cast iron with stainless steel, and asked if anyone had experience cladding. There was a lot of discussion about how the cooktop worked, and other possibilities, but no one had cladding experience.

A member bought a Lincoln Weld-Pak at a garage sale. He found that the wire feed mechanism didn't work. A welding repair shop said that a PC board was probably defective, and was too costly to repair. Another club member said that he had fixed several similar welders. He thought that it was unlikely that it was a complicated circuit board, since the welders only had simple relays and such on the PC board. The typical failure that he has seen was in the rotary switch used to change the welding current. If it's changed while welding, the switch could be damaged. On the less expensive welders, the welding current supply and the wire feed mechanism use power from the same circuit. Repair could be as simple as repairing the contacts on the switch.

A member wanted to make an oven on a cart to anneal and temper steel, and asked advice on construction. Another club member said that he should concentrate on burner technology, and that there was a lot of information on that subject on the web. He should consider using High Temperature Wool instead of fire bricks to hold down the weight. Another method of annealing is to use a salt bath. Table salt is good for temperatures up to 960°F. Another benefit to salt is that the salt coating protects the metal while cooling.

## Novice SIG Activities

*Rich Pichler* and the Novice Group talked about using half-round files to clean out pipes.

## Articles

## Compact Radial Bender

By Dick Kostelnicek



This radial bender can form arcs in both wire and flat stock up to 1/8-inch thick. Additionally, it will bend 1/4-inch material that is heated dull red hot. It accommodates material up to 1-inch high with inside bend radii between 1/4 and 1-inch by using 9 round mandrels. I first saw this style of radial bender in a 1968 Popular Mechanics article in the Do It Yourself Encyclopedia, page 257.

The bender's head has a large hex base that facilitates clamping in a vise at six different orientations. A 1/2-inch elevation bolt is screwed into the head's bottom to support the bender's substantial weight on a vise cross beam (right photo).

The bolt, once set, is fixed with Loctite or a thick wrap of Teflon pipe tape to prevent it from turning as the head is positioned in the vise.

I altered the method of clamping the work against the round center mandrel by using a stepped, 4-sided, flat-faced clamp pin along with a clamp screw (photo 2 below). This method holds the work snugly against the mandrel and prevents it from being pulled out from under the clamp pin as the peen or forming nose is swung around. I made two clamp pins, one with flat faces increasing and another decreasing in 1/32-inch steps. The larger pin has two 1/4-20 tapped cross holes for a screw that forces the work against the mandrel. This clamping method will accommodate a wide range of work thicknesses.

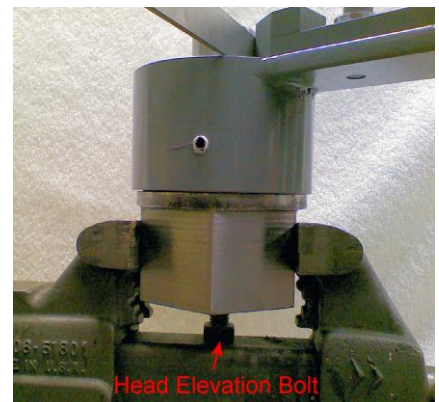

## Home Metal Shop Club Newsletter

The peen has a high abrasion resistant nose made from a 3/16-inch diameter round carbide tool bit that is silver soldered in its pointed end. The drawing at the end of this article shows the peen made from a 1-inch square bar with nearly half of it being milled away. My peen, however, was built up from two stacked pieces of 1 X 1/2 – inch mild steel (right photo). The two pieces were aligned with dowel pins and subsequently silver soldered together, thereby, saving a lot of material and mill time. The peen was initially made a bit longer than that show in the drawing, so that the 3/16–inch vertical nose piece hole could be drilled and reamed in solid material. After silver soldering the round tool bit in place, the two sloping faces of the peen were finished tangent to the tool bit with a vertical belt sander.



The 4.25 inch OD head collar was made from a 3-inch threaded pipe coupling. Simply boring out the

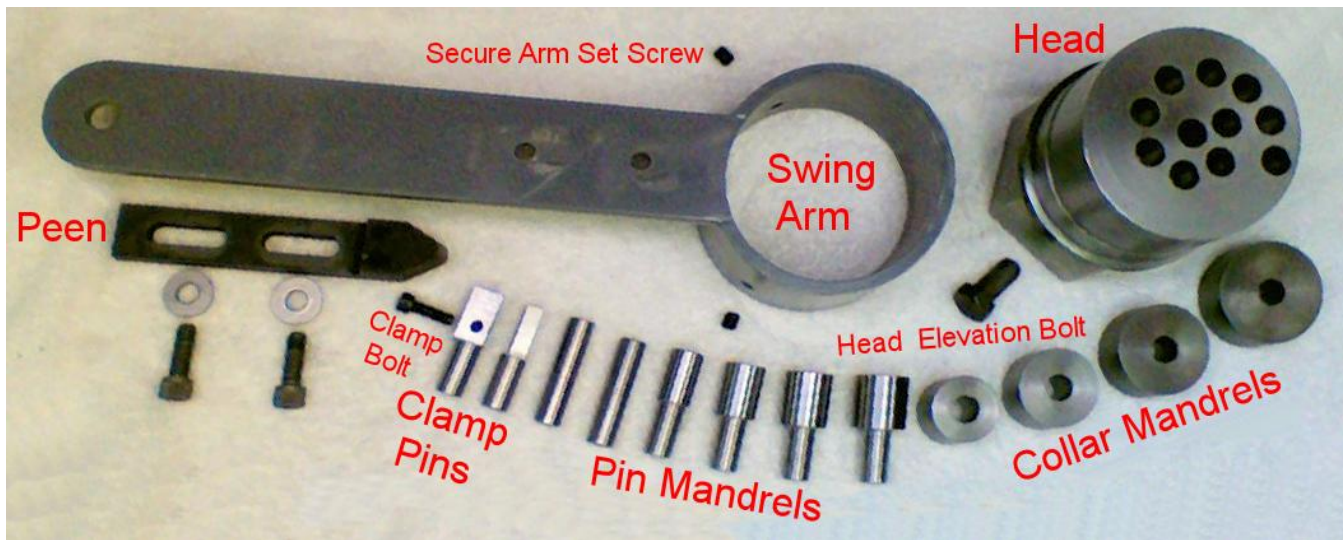

internal threads to 3.75 inch ID will yield just the right sized material for the collar. The swing arm's handle was brazed to the head collar. After brazing, I smoothed the handle's curve with a vertical oscillating drum sander to match the inside radius of the head collar. A rat tail file would serve as well here.

The swing arm is secured from lifting off the head by two cup point set screws that ride in a groove around the head's circumference. These screws are engaged just shy of touching the bottom of the groove and are fixed with Loctite or Teflon tape. Wheel bearing grease was placed between the head and the swing arm collar to give a viscous feel as the arm rotates.



Thick work tends to pull out from under the clamp pin. This can be prevented by firmly grabbing the material being bent with a Vise Grip on the side opposite from where the bend is being performed (left photo). Alternatively, just tighten the clamp screw in the clamp pin (photo 2 below).

The small pin mandrels are made from drill rod and range in diameter from 1/2 to 1-inch. Each has a 1/2-inch diameter bottom post that fits into the center hole on the bender's head. For larger bends, collar mandrels fit over a long 1/2-inch diameter pin.

The clamp holes in the head are arranged in a spiral about the central mandrel hole. The clamp pin locations are shown below in the table labeled "Hole Locations for Pins in Head". The first four holes spiral outward with an increment of 1/16-inch. The remaining holes are successively 1/8-inch farther from the center. This spiral arrangement provides for tight clamping of inside bend radii that range from 1/4 to 1-inch. The two flat clamp pins allow material as thin as 1/32-inch thick and increasing in 1/32-inch steps to be held firmly against the mandrel.



The parts for a scroll shelf bracket, shown at the left, were bent as illustrated in photos 1 through 5 shown below. The bracket was made from 1/8 x 3/4-inch cold rolled steel, silver soldered together, and Parkerized to prevent rusting. First a 1/4-inch radius 90-degree bend was made on the outer straight sided portion as seen in photo 1. The initial scroll bend is shown in photo 2. The clamp screw prevents the material from pulling out from under the clamp pin. The short straight portion of the material, held under the clamp pin, was later sawed off with a vertical band saw. Photo 3 shows the reverse bend of the scroll. The material was then removed from the bender, sawed to length, and the bend was nearly completed as seen in photo 4. To finish the end of the bend, the work was repositioned so that the peen cleared the clamp pin as shown in figure 5.

The material was then removed from the bender, sawed to length, and the bend was nearly completed as seen in photo 4. To finish the end of the bend, the work was repositioned so that the peen cleared the clamp pin as shown in figure 5.

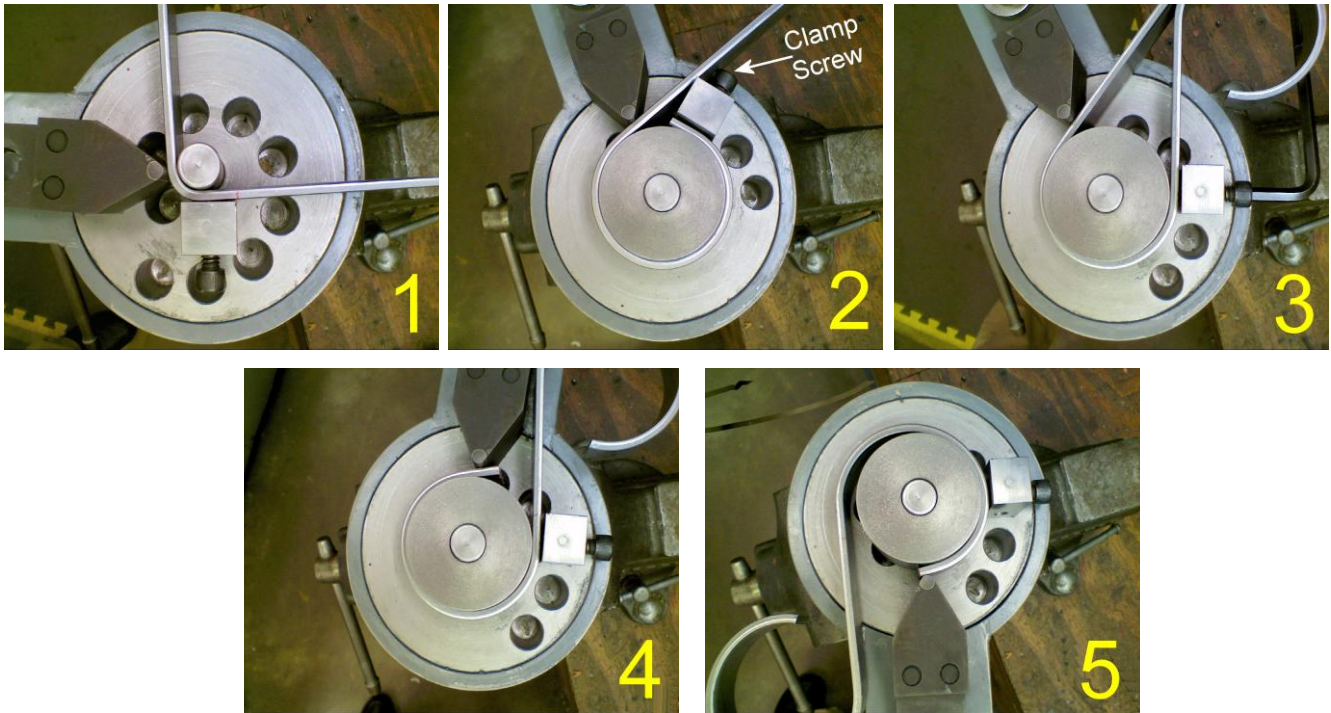

[Click here](#) to view a video of a similar powered arc bender.

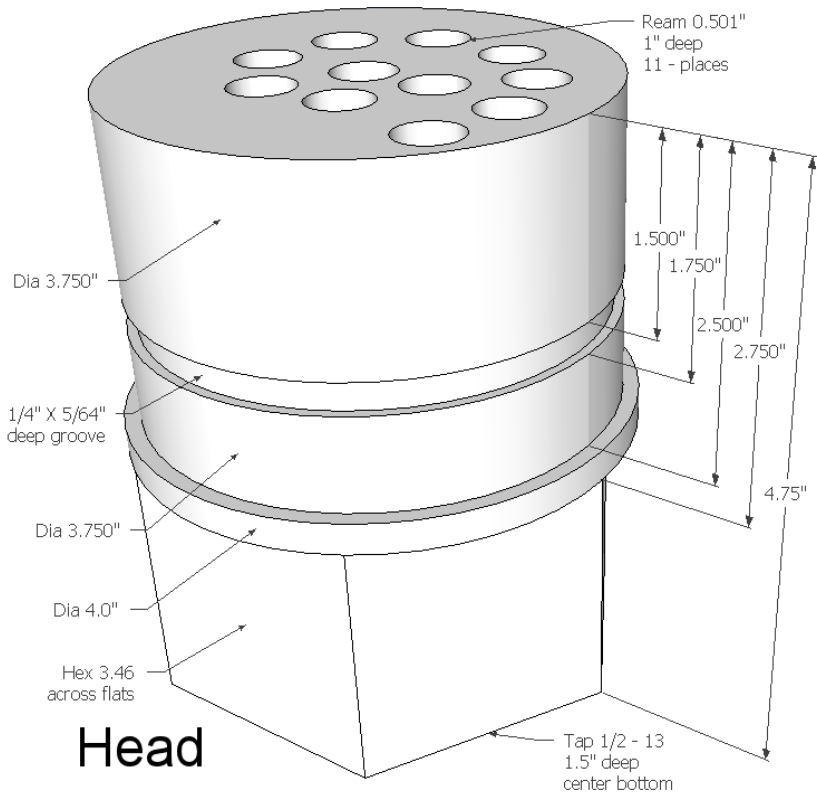

Hole Locations for Pins in Head				
Hole #	Radius	Angle(deg.)	X-location	Y-location
0	0		0	0
1	0.625	0	0.625	0.000
2	0.688	64	0.301	0.617
3	0.750	119	-0.363	0.655
4	0.813	172	-0.804	0.116
5	0.875	-139	-0.660	-0.574
6	1.000	-95	-0.087	-0.996
7	1.125	-55	0.645	-0.922
8	1.250	-23	1.151	-0.488
9	1.375	7	1.365	0.168
10	1.500	35	1.229	0.860

All positions measured from center of bender head. Negative values in red.

Note: You may want to reduce the top round and bottom hex portions of the head to conserve weight and material.

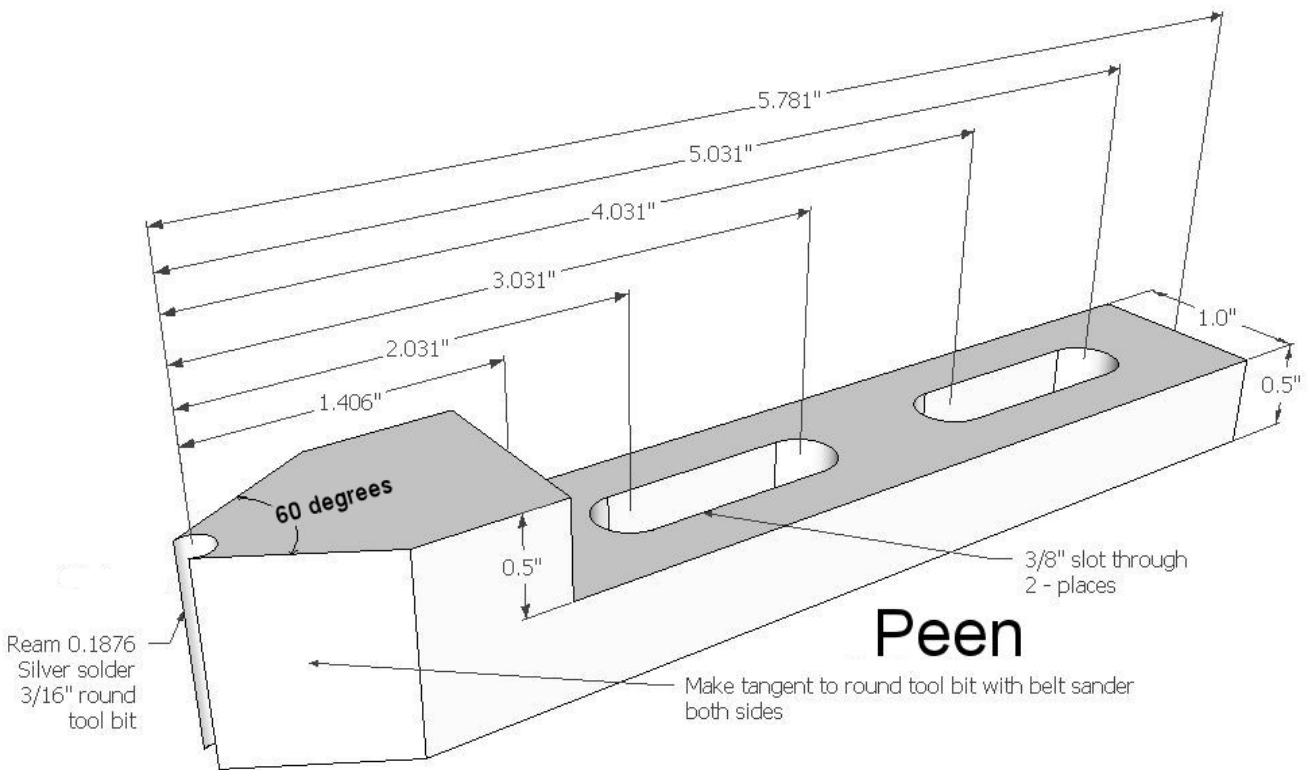



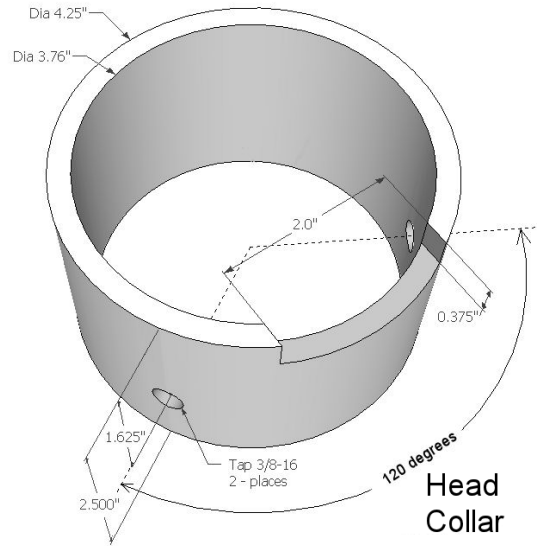
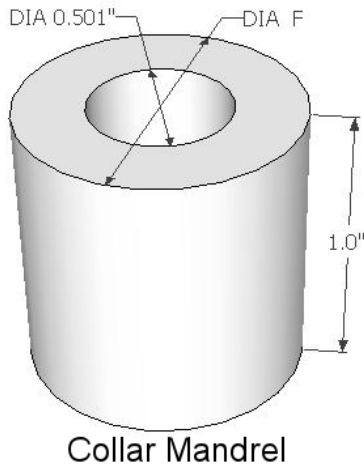
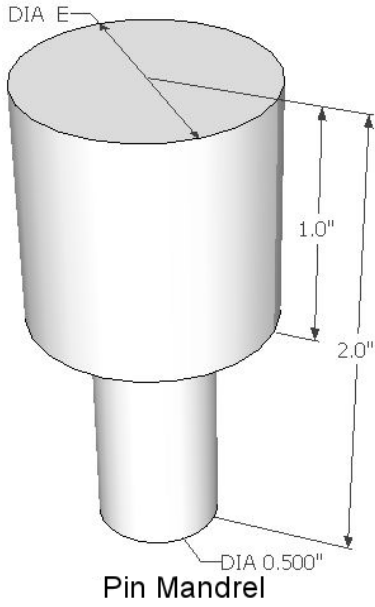

E	F
0.5	1.25
0.5	1.5
0.625	1.75
0.75	2
0.875	
1	

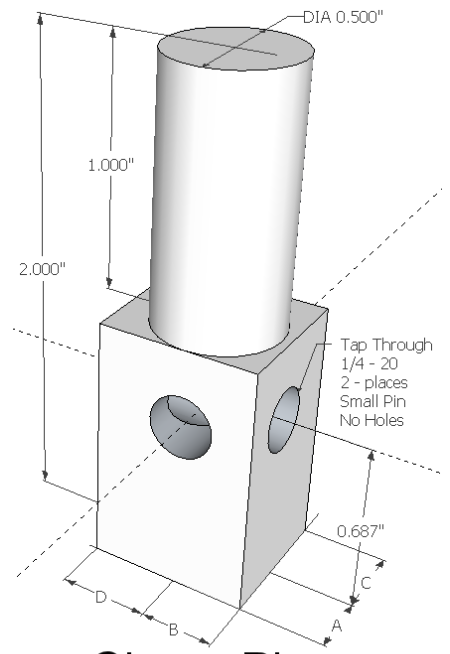

Bar Stock Dia.	A	B	C	D
5/8"	0.125	0.156	0.188	0.219
7/8"	0.25	0.281	0.313	0.344

