

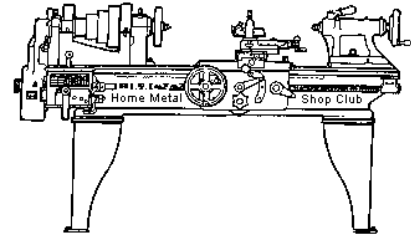

May 2015
Newsletter

Volume 20 - Number 5



<http://www.homemetalsclub.org/>

The Home Metal Shop Club has brought together metal workers from all over the Southeast Texas area since its founding by John Korman in 1996.

Our members' interests include Model Engineering, Casting, Blacksmithing, Gunsmithing, Sheet Metal Fabrication, Robotics, CNC, Welding, Metal Art, and others. Members enjoy getting together and talking about their craft and shops. Shops range from full machine shops to those limited to a bench vise and hacksaw.

If you like to make things, run metal working machines, or just talk about tools, this is your place. Meetings generally consist of **general announcements**, an **extended presentation** with Q&A, a **safety moment**, **show and tell** where attendees share their work and experiences, and **problems and solutions** where attendees can get answers to their questions or describe how they approached a problem. The meeting ends with **free discussion** and a **novice group** activity, where metal working techniques are demonstrated on a small lathe, grinders, and other metal shop equipment.

President <i>Vance Burns</i>	Vice President <i>Norm Berls</i>	Secretary <i>Joe Sybille</i>	Treasurer <i>Emmett Carstens</i>	Librarian <i>Ray Thompson</i>
Webmaster/Editor <i>Dick Kostelnicek</i>	Photographer <i>Jan Rowland</i>	CNC SIG <i>Martin Kennedy</i>	Casting SIG <i>Tom Moore</i>	Novice SIG <i>Unfilled</i>

This newsletter is available as an electronic subscription from the front page of our [website](#). We currently have over 834 subscribers located all over the world.

About the Upcoming 13 June 2015 Meeting

The next general meeting will be held on 13 June at 12:00 noon at the [Barbara Bush Library](#) that is located at [6817 Cypresswood Drive](#) - Spring, TX 77379. Chris Marvel will give a presentation on Non-Ferrous Heat Treating.

Visit our [website](#) for up-to-the-minute details, date, location maps, and presentation topic for the next meeting.

General Announcements

[Videos of recent meetings](#) can be viewed on the HMSC website.

The HMSC has a large library of metal shop related books and videos available for members to check out at each meeting. The library is maintained by the [Club's Librarian, Ray Thompson](#). These books can be quite expensive and are not usually available at local public libraries. Access to the library is one of the many benefits of club membership.

The club has funds to purchase new books for the library. If you have suggestions, contact the [Librarian](#).

We need more articles for the monthly newsletter! If you would like to write an article, or would like to discuss writing an article, please contact the [Webmaster Dick Kostelnicek](#). Think about your last project. Was it a success, with perhaps a few 'ugh ohs' along the way? If so, others would like to read about it. In the September 2012 HMSC board meeting, the board elected to waive membership fees during the next membership renewal cycle for those providing newsletter articles.

Ideas for programs at our monthly meeting are always welcomed. If you have an idea for a meeting topic, or if you know someone that could make a presentation, please contact [Vice President Norm Berls](#).

Recap of the 9 May 2015 General Meeting

By Joe Sybille, with photos by Jan Rowland



Twenty-two members, including one new member, Mike Hinz, attended the noon meeting at the Spring Branch Memorial Library, 930 Carbindale Street, Houston, TX 77024. Welcome to the club Mike. No visitors attended today. There are 58 members in good standing.



President *Vance Burns* led the meeting.

Presentation

Club member *Norm Berls* (right photo) gave a presentation on *How to Achieve the Best Possible Results with a Rong Fu Mill-Drill*. Norm began his presentation with a description of a new work table for his mill-drill. Compared to his former one, the new



table is heavier and sturdier with a ½ inch thick steel top and 4 inch square steel tube legs. Weighing approximately 350 pounds the table is 24 inches wide by 32 inches deep by 27 inches tall.

Mounting the mill-drill proved to be challenging. Norm used an engine hoist with a two ton capacity and a lifting jig custom made for the mill-drill to place the mill-drill onto the table. Once in place, he bolted the mill-drill to the table and set about trammig it. One of the reasons for the new table was that the old one flexed too much and Norm had to readjust frequently the tramm of the mill-drill. Upon mounting it on the table, he installed new tramm rods between the mill column and base. With a dual indicator trammig gage he continued the tedious task of trammig the mill-drill. Problems arose after mounting the milling vise on the mill-drill. Norm discovered an 0.011-inch difference between the front and back edges of parallels placed in the milling vise.

Additional trials with the trammig gage proved troublesome. Norm gave up on the use of the trammig gage and resorted to using a machinist square and a drill rod chucked in the collet. The goal is to get the mill-drill work table perpendicular to the drill rod. A small piece of wax paper served as the feeler gage to indicate perpendicularity between the work table and the drill rod. Adjustments of both the x-axis and y-axis tramm states must be taken into account simultaneously, since adjusting the tramm for one axis without considering the other only leads to one axis in tramm. Ultimately, readjustment of the tramm bolts succeeded in trammig successfully the mill-drill.

Next came the DRO (digital readout) error correction for both the x-axis and y-axis travel of the worktable. Using height gages clamped to the mill-drill work table, Norm made adjustments to zero the DRO for accurate readings on both axes.

Finally, Norm discussed methods of work that he uses in his shop and with his mill-drill. Among the methods discussed were the use of a reciprocating saw to cut off big pieces of mild steel and aluminum and the use of progressive drilling techniques to make large holes. Progressive drilling entails making a hole by using progressively larger bits to get to the final hole size. I often use a 1/8-inch engraving bit to set and refine the alignment of the drill chuck with the hole to be drilled. Then I use a 135 degree included angle to bit prevent walking of the drill bit.

The use of mechanical edge finders and center finders get plenty of use in Norm's work scheme. With his mill-drill, Norm prefers short ½-inch HSS (high speed steel) end mills for most cutting. His cutting fluid of choice is Mike-O-Cut for steel and A-9 for aluminum. He uses 4 flute end mills on steel and 2 flute end mills on aluminum. For roughing work in steel, Norm uses a fine tooth roughing end mill. For near-finished work, he prefers a smooth cut end mill. He uses a carbide burr for final cuts and a grinding stone to get the finest finish.

When making cuts with the Rong Fu mill-drill, Norm limits his cuts to no more than 0.030 inches. The recommendations found in Machine Shop Know-How by Frank Marlow, PE and P. J. Tallman have served Norm well. For example, depth-of-cut limits are as follows.

1. Off the side of a mill <0.1 Diameter of mill.
2. Off full end of a mill 0.5 Diameter of mill.
3. Off partial end of a mill <0.9 Diameter of mill.

Norm limits the speed for drilling holes and milling with his Rong Fu unit to the following values.

Drilling mild steel

1000 rpm for 1/8-inch bit
700 rpm for 1/4-inch bit
300 rpm for 3/8-inch bit
100 rpm for 1/2-inch bit

Milling mild steel

700 rpm for 1/2-inch HSS end mill
1000 rpm for 1/2-inch carbide end mill
1000 rpm for 1-inch grinding stone

For holding work, Norm uses a large heavy duty vise on his mill-drill. The movable jaw is forced downward onto the vise base when the screw is tightened and ensures the work is held securely. Assorted vise jaws with glued on magnetic backs, rubber faces, and v-slots for round objects stay in place in the vise and prevent marring of work pieces.

Norm is sold on the utility of the power feed, for the power feed enables his mill-drill to make repeatable cuts. Without this accessory, the Rong Fu made consistently cuts of irregular depth.

Overall, Norm considers his Rong Fu mill-drill adequate for hobby work, but unsuitable for precision production work. The X and Y controls work well. The Z control is inconsistent and is the major shortcoming with this mill-drill.

[Norm's presentation slides can be viewed at this web link.](#)

Safety Moment

Vance Burns showed a video on safety in the workplace with an emphasis on multi-tasking. Multi-tasking is, at times, productive, but there are inherent risks in doing so. It is important to keep one's mind on a task. Sometimes the nature of the task at hand prevents one from devoting one's attention to more than one task.

David Bellinger recounted an incident whereby a shop worker sustained an eye injury while using a grinder. The worker wore loose fitting safety glasses and metal fragments flew from the workpiece into the eye of the worker, bypassing the rim of the safety glasses. Proper fitting safety glasses would have prevented this injury.

Norman Gouger, Sr. shared with the membership an incident in which he, while on a ladder, fell three feet to the floor. The fall resulted in a broken leg and an injured shoulder, both requiring extensive medical treatment. Norman was in hurry and took a short cut.

Emmett Carstens spoke of an incident whereby a former co-worker working at home injured herself while on a wooden 6 foot step ladder. The ladder legs collapsed resulting in fragmented wood piercing the lower legs of the co-worker. The injuries required medical treatment.

Show and Tell



Dick Kostelnicek showed the results of an intricate design in a thin piece of stainless steel. A laser cut out the design (right photo).



Rich Pichler exhibited a mold for making 3-inch diameter cannon balls (left photo) .

Tom Moore demonstrated a technique for placing in a lathe chuck both carbon and stainless steel washers. (Photos below.)

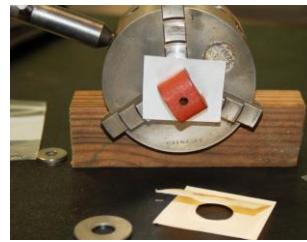
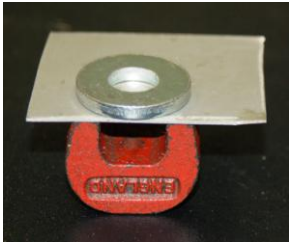

Problems and Solutions - *Ask the Blacksmith*

A member discovered the saddle that mounts on the ways of his Smithy lathe has side surfaces that are not perpendicular. He wanted to know the best way to true the sides. Suggestions offered ranged from sending the saddle to a machine shop to using a fly cutter to true the surfaces.

Another member wanted to know the use of certain tools in a machinist catalog. He showed on a screen projection several catalog items. The member's inquiry prompted a lively and informative discussion on the use of many tools found in a machinist catalog.

Novice Sig

There was no sig activity during the meeting.

Articles

Piston Ring Adventure

By Alan May

My current four cycle engine project needs piston rings for its 1-inch diameter cylinder. My experience with piston rings was nil. The plans suggested a couple of sources, phone numbers only, and no internet sites. I called one, and ordered six 1-inch rings. I assumed that they would be sized properly for a typical a 1-inch cylinder. I hadn't done much research at that point. At my age I should have known better.

The rings turned out to be much larger than the suggested dimensions and they did have a nice overlapped gap. Suggested maximums for a 1-inch cylinder are 0.040-inch for both thickness and width. These were 0.050-inch thick by 0.125-inch wide. The rings were also covered with scale. I made a piston to fit these rings adjusted their gap and with considerable difficulty, installed them in the bore. There was so much friction that it took a hammer to slide the piston in the cylinder. It didn't seem right, so I hammered the piston out of the cylinder and then tried to remove the rings. I broke all three in that process. I then decided that I was going to have to make my own rings.

So, I started reading everything I could find about making rings. It seems the problem with making piston rings is to make them perfectly round while exerting omni directional force against the cylinder walls. Dick Kostelnicek wrote a great article about making piston rings, available [on the HMSC website](#). He decided to make his rings with an off center ID. To make this work, the thick part of the ring is to be 4 times the thin part. If the thin part is 0.020-inch, about the smallest I am inclined to go, the thick part will have to be 0.080-inch. The ring groove should be about 0.084-inch deep all around. I wonder how the 0.020-inch section will work floating in a 0.084-inch groove. So I decided to continue my research. I cornered Dick at the last HMSC meeting, and he told me they worked just fine.

On Jerry Howell's website, I found an article by Mick Collins on making pistons rings. Jerry Howell designed a number of model engines, and the plans are sold on his website. I have had very good luck with his plans. It has several pages of engineering discussions about ideal ring pressure against the cylinder. The following is my edited version of [Mick's suggestions from his web article](#).

First, finish the cylinder bore - to diameter D.

Decide the cross section of ring required and, if you are using a conventional, non-demountable, piston then finish it, making the ring grooves deep enough to give 0.004-inch clearance behind the rings.

Make the steel sleeve for the machining fixture, bored to $D+0.002$ -inch and approx D long. (See drawing below, I like $D+0.006$ -inch. AM)

Chuck a length of centrifugally cast iron and drill it to within 1/16-inch of the inside diameter of the rings for sufficient depth.

Turn outside diameter to $D+0.002$ -inch (use sleeve as a gauge) for a length equal to: $(w + \text{parting tool width}) \times \text{number of rings required plus a few spares}$.

Use a narrow parting tool to make a series of grooves. Depth of grooves to be exactly equal to $t + 0.001$ -inch. Spacing to be exactly $w + \text{parting tool width} + 0.001$ -inch (lapping allowance).

Now use a sharp fine boring tool to open up the hole to inside ring diameter. As you approach this, reduce the cut to 0.001-inch and 'lean' on the tool to prevent it cutting 'on the way out'. When you reach the final cut you will be rewarded by a little bunch of rings on the neck of the tool. (Or likely the whole cylinder in uneven pieces.AM)

Use a Swiss file to break the sharp corners inside the rings so that they will move freely to the bottom of their grooves. (Small Mototool grinding point at slow speed works well for corners. AM)

Make a tiny nick on the inside of each ring with a very fine triangular needle file and break it between finger and thumb, or by using the thumb to press it down onto a piece of wire on a flat surface. Very carefully dress the broken surfaces with a Swiss file (No 6 cut) (I use pliers. AM)

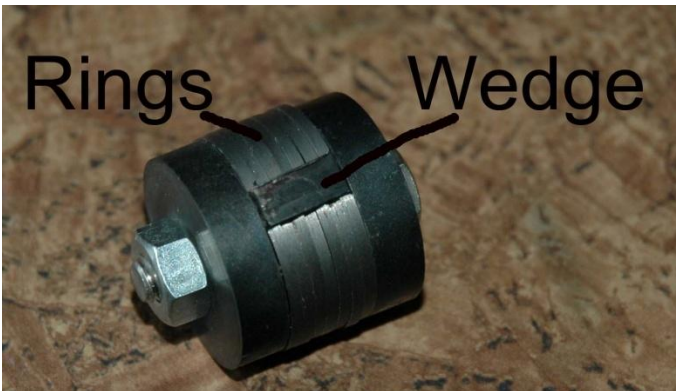

Make the wedge to hold the gaps open.

Stack the wedged rings around a bolt, clamp them between two steel plates and heat evenly to 550 - 600 C (900 - 1,000 F), i.e. just visible in the dark, NO HOTTER! Hold at this temperature for 10 minutes and then allow to cool. The rings should not have scaled. (I've done this successfully on an electric cooker hot-plate, which can be set to the correct temperature first and then the rings laid on it and left for 30 minutes. A picture of my version is at the left. AM)

Next make the machining fixture shown in the diagram on the next page.

Pack the rings into the sleeve and slide the sleeve on to the rod. Fit the disc and clamp rings securely with the nut. Slide off the sleeve and use the engine cylinder as a gauge to take a 0.001-inch cut off the rings and reduce their diameter to D.

Finally, lap the sides of the rings to fit their grooves. They should be perfectly free but with a clearance of only 0.001-inch or less.

This article was a pretty good starting point for me, but I made some changes. The idea of precisely plunging the cut off grooves 0.001-inch deeper than the final ring ID before boring the final ring ID is something I won't even attempt. The idea is that the ring will neatly drop off when the final ID is cut. I know that if I tried this, I would probably cut the most left hand groove 0.001-inch too deep and then the whole cylinder would drop off before I had any rings at all. I just don't think the best way to achieve a precise ID is by the controlling the depth of the cut off groove.

I also found that 0.002-inches initial oversize was too little – only a 0.001-inch depth of cut. After heat treatment, the ring's OD was more than 0.001-inch irregular. The rings are cut from round stock. So I tried 0.006-inch oversize which allows 0.003-inch depth of cut. I had to make a new fixture of course.

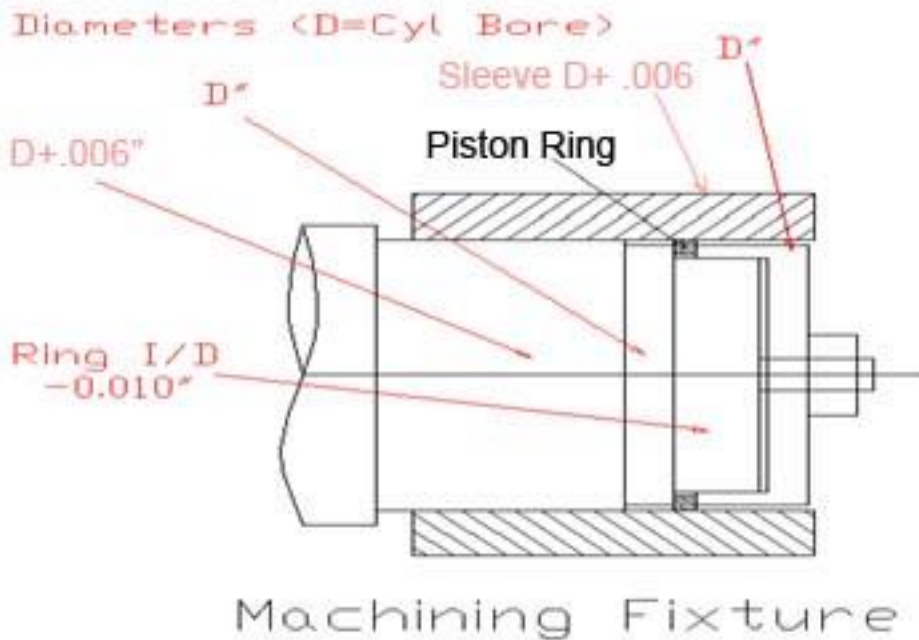

I tried to perform the heat treat of my first batch with a propane torch, but that was pretty much a failure. I am sure I got them too hot, and I didn't leave much spring to them. I found that when I coated them with heat shield I could not tell if they were barely red or not. So, I kept the torch going, the heat shield peeled off, and I could see they were bright red. I made a test installation with modest success, but broke them when I tried to remove them. So, I obtained the use of a small oven.

Collins says the heat treatment should be 900 – 1,000 F for 10 minutes, Dick suggests 1,500 F for 15 minutes. I tried both, and 1500 F for 15 minutes seems better. After 1,000 F for 10 minutes, my rings broke easily. I could get a few on the piston, but was never able to remove any without breaking them.



Collins says there will be no scale at 1,000 F. The oven literature says there will be scale at temperatures over 875 F. I believe the oven. Some say cool slowly, some say quench is OK. I put a fan on them to cool. I made the fixture for shaping final OD described above, and some others.



I tried to hold rings in a recess cut in an emergency collet but the rings had too much flex to seat solidly. When I tightened it up, they would bulge out in places. So, I made an expandable arbor for machining the width (or height.) It has a 20 degree wedge which releases easily. Note the 1/8-inch



grooves which are wide enough to accommodate a dial caliper without removing the ring. It works only on unbroken rings. There is an undercut in the arbor's inside corner, and I tap the rings with a small brass hammer to be sure they are seated. Later, I found that I could come very close cutting off at the proper width so I didn't use it to adjust width.

I found that holding the rings by hand to lap the sides produced uneven ring widths, more metal is removed where the fingers pressed. My finger saver has some weight which seems to help. The notches are there to ease removal of a ring that is a tight fit. For lapping, I use emery paper on my saw table.

I made a ring expander using snap ring pliers with removable points. This tool is really necessary. Without it I broke any rings I tried to remove rings from a piston. Also, an ordinary hose clamp makes a nice ring compressor and really helps installing the piston.

I made a second batch of rings from a new cast iron rod. I could not break them by hand or by pressing on a 1/8-inch rod, which worked for the first batch. However, I found that two pair of pliers worked perfectly. I suppose this is cheating, almost everything I read says to use your fingers, but these parts have real sharp corners. I slice my fingers enough by accident. I found an example suggesting rings be broken by putting them in a vise, which should work.



I work the gap with a Mototool thin friction disk which seems to work OK. I use the old style small brown ones that break all the time. Three or four light touches on each end of the gap. I found considerable discussion about the installed gap on the internet. If it is too small the ring cannot flex so slight imperfections in the cylinder will cause excess friction at best, and often disaster – broken rings or pistons. I work the gap until the ring will slide nicely in the oversize sleeve which is part of the machining fixture. Even so, I found that I always had to widen the gap again as a last step. The test is to slide them in the sleeve or the cylinder, they should move nicely. As we all know, if you put a 1-inch OD in a 1-inch ID, it won't move without a hammer. I use the arbor to hold the rings open before heat treatment, and drill press vice after for working on the gap. One essay on the subject claims that a gap as much as 0.006-inch is that not a major leak problem. But the sides are very important, they must be flat and fit well.

The Collins article finishes by suggesting that the machining fixture be hardened and used as a file (diamond file) guide to reduce the rings to their final diameter. I used a tool with a very sharp braised carbide edge. I have had trouble removing 0.001-inch with a carbide insert with a chip breaker groove. When I advance only 0,001-inch, nothing much happens at first, so I advance another 0,001-inch and get a half. Advance again, and I get too much. But I can get good results for very small cuts with HSS or braised on carbide chips. I make sure they are really sharp.

My research indicates piston and ring dimensions should be:

- Piston diameter - cylinder bore less 0.002-inch
- Rings thickness – 1/25 – 1/30 of cylinder bore
- Ring height – same at thickness

May 2015 - Home Metal Shop Club Newsletter - V. 20 No 5

- Compressed gap - 0.001-inch + 0.001-inch per inch of cylinder diameter
- Uncompressed gap – 4 x thickness
- Ring groove width – ring height + 0.001-inch or less, ring should move freely
- Ring groove depth – thickness + 0.004-inch

The project plans I am working on calls for rings 0.063-inch wide and 0.055-inch thick, a departure from the guidelines. When I started this part of the project I had already made the piston, so I followed the plans.

My Procedure:

- Turn cast iron cylinder; OD - to project cylinder diameter + 0.006-inch; ID – project cylinder diameter less final ring thickness. It should be long enough for a number of extra rings plus cut off tool width. If three are needed, make 8 or more.
- Cut off rings 0.002-inch oversize. Measure 2nd ring cut and adjust tool advance as necessary. (The first cut will be off a little because the starting point may be imprecise.)
- Lap sides to final width. Use piston as a go gage.
- Relieve inside corners. Mototool with grinding point works well.
- Break gap. Pliers work well.
- Enlarge gap using Mototool friction disk. Test by sliding the ring into the fixture sleeve. It should slide nicely. It is easy to tell when the gap is too small.
- Clamp in heat treat fixture and heat – 1500F for 15 minutes.
- Polish sides as necessary.
- Mount several rings in a machining fixture and reduce to cylinder diameter. Use a very sharp tool and a micrometer.
- Recheck gap using cylinder as a go gage. Ring should slide nicely in cylinder.

Metal Finishing

by *Dan Harper*

This article describes some surface treatments for metal. Chemical treatments create little to no surface build-up. If it is desired to increase the dimensions of a part, coatings such as paint, ceramics, powder coating, plating, or another process may fill the need.

Changing the appearance and surface characteristics of the part can be done with chemical processes. Chemical methods ranges from the simple and relatively safe procedures described here to industrial processes involving toxic chemicals and elaborate safety precautions.

Basic Chemistry

- Acids act on most metals, as well as firearm bluing.
- Acids are neutralized by alkalis (bases).
- Alkalis (bases) act on aluminum.
- The chemicals work better if oily residue is cleaned from the parts before beginning.
- The stronger the chemicals, the faster they work.
- The stronger the chemicals, the more closely the reactions must be monitored.
- The stronger the chemicals, the more safety precautions are needed.
- Learn unfamiliar processes on test specimens, not valuable items.

Vinegar is 5% acetic acid (pickling vinegar is 9% acetic acid). The active ingredient in Naval Jelly is phosphoric acid. Colas also contain phosphoric acid. Muriatic acid is dilute hydrochloric acid. The electrolyte in lead/acid batteries is sulfuric acid. Acid also attacks concrete and can be used to clean concrete from tools and bricks.

Acid reactions generate hydrogen gas. Therefore, use plastic containers that will not hold pressure, and keep them away from flames.

After acid treatments, wash the part in water and neutralize any remaining acid with an alkaline solution such as one or more spoonfuls of bicarbonate of soda (baking soda) in enough water to wash the part.

If a surface treatment is to be applied after acid treatments, have it ready to be used immediately. If the steel is to remain bare, coat the still-wet surface with synthetic motor oil (synthetic oil won't get dry or gummy), and thoroughly dry the wet, oily part.

Removing Rust from Steel

Rust can be mechanically removed from steel by using sandpaper, Scotchbrite, scrapers, wire brushes, and sandblasting.

Rusted parts can also be cleaned by soaking in acid or with Naval Jelly. Use milder methods for light rust and more aggressive techniques for heavier rust. After the rust is gone, wash the part in water, neutralize any remaining acidity, oil the wet surfaces, and dry the part.

There are also proprietary chemicals which are claimed to remove rust without harm to the underlying steel.

Preserving Delicate Steel Surfaces

A rusty part with precision surfaces or paint or decals to be preserved can be *patiently* restored. The tannic acid in tea is a slow and gentle rust remover. Get a large box of tea bags from the supermarket. Ignore antioxidant claims and brand names, the cheapest works as well as any.

Put enough cool water in a container to cover the part and add enough teabags to make a solution several times stronger than what you would drink. Put the part in the container and wait. The water will turn black and a line of tiny bubbles will probably form, outlining the edges of the part.

After several days, when the reaction appears to have stopped, pour off the black water and discard the teabags. The black residue stains, so keep it away from your clothes. Scrub the part with an old toothbrush, being careful of paint and decals, and wash it in water.

Repeat the tea-soaking and scrubbing process several times until the rust has been removed.

Wash the part in water, neutralize any remaining acidity, oil the wet surfaces, and dry the part.

Preventing Steel from Rusting

Steel wants to return to the iron oxide from which it was taken, particularly in humid climates. Rust can be kept at bay by applying surface finishes, lightly oiling the parts, or keeping them in oiled paper or oiled boxes. A protective oil film should be renewed after an item is cleaned with solvents or water.

Removing Existing Coatings from Steel

Zinc plating can be removed from parts, such as hardware store bolts, by soaking them in vinegar or another acid, or using Naval Jelly. Pickling vinegar (9%) will remove the plating from hardware store bolts in several hours to a couple of days. Stronger acids work faster, but may attack the underlying steel, as well as skin, clothing, floors, and anything else it touches.

When the plating is gone, wash the part in water, and neutralize any remaining acidity. If a surface treatment is to be applied, have it ready to be used immediately. If the steel is to remain bare, coat the still-wet surface with synthetic motor oil and dry the wet, oily part.

A Gray Rust-Resistant Finish for Steel

Steel can be given a rust-resistant gray surface by soaking the part in vinegar. The part will slowly turn gray. After a day or two, clean off any black residue, and return the part to the vinegar bath. Repeat the soaking and cleaning until the part is as dark as it will get. Soft steel usually gets darker than harder steel.

Wash the part in water, neutralize any remaining acidity, oil the wet surfaces, and bake the wet, oily part at about 250°F for about 20 minutes. This finish is a good choice for an item that will be used dry (i.e. not oiled).

This process will not hide scratches or machining marks. If surface imperfections must be removed, use sandpaper before chemical treatment, and/or experiment with stronger acids. Because stronger acids may cause dimensional changes, (including rounding sharp edges) precision work may need to be completed after the surface treatment. Protect the surface from vise jaws and newly created chips.

Black Rust-Resistant Finishes for Steel

Steel can be given a black rust resistant finish by using "cold bluing" chemicals available from gun shops and sporting goods stores. Cold bluing creates an extremely thin layer of oxides on the surface of the metal.

There are a number of brands on the market. Some work better than others, some work better on different steels. Two good ones are Oxpho-Blue and 44/40 from Brownells.

Follow the directions on the package. Multiple treatments create a darker and more durable finish. These processes usually work better on (gently) heated parts. The dry surface may have uneven colors, but these variations will disappear when the part is oiled.

A Silvery Matte Finish for Aluminum

Aluminum can be given a silvery matte finish by etching it with alkaline chemicals such as Zep Industrial Purple cleaner and degreaser. (Simple Green is less alkaline and parts can soak in it for weeks with little visible result.) This is an appearance treatment, not hard anodizing; the surface durability is not increased.

If machining or extrusion marks, or other surface imperfections must be removed, use sandpaper before chemical treatment. Because strong alkalis may cause dimensional changes, (including rounding sharp edges) precision work may need to be completed after the surface treatment. Protect the surface from vise jaws and newly created chips.

Zep Purple works fast. Use it in a sink and wear rubber gloves and eye protection. Place the part in a plastic bag and pour undiluted Zep over the part. In order to use less Zep, hold the bagged part in your hands (rubber gloves!) and compress the bag to keep the part covered. The reaction will foam vigorously. After about a minute, pull the part out (place the bag in a bowl), wash it in water, and check the appearance of the surface. Put the part back in the bag a little longer and check it again. When the appearance is what you want, wash the part thoroughly.

Further Reading

The Complete Metalsmith, An Illustrated Handbook, by Tim McCreight

This book explains alloys, shaping metal, casting, joining, surface finishes, and much more. The author explains the basics, and does not presume that the reader has extensive metalworking experience. The approach is art metal and jewelry, but many of the processes can be applied to other types of work (but only if you know about them).